

Technical catalogue



Pressure fittings in PVC-U



General characteristics

PVC-U

Developed in 1930 in Germany, PVC-U (rigid polyvinyl chloride - unplasticized) is obtained through the polymerization of a vinyl chloride monomer. The presence of chlorine in the PVC-U molecule results in a high performance resin, in terms of thermal stability and chemical and mechanical resistance, up to temperatures of 60° C.

The different formulations obtained by adding suitable additives and stabilizers render the PVC-U the most versatile of all plastic materials, allowing it to be adapted to many applications involving fluids under pressure.

PVC-U represents one of the more economic solutions in the field of thermoplastic and metal materials for resolving problems in the transport of corrosive chemical fluids, and in the distribution and treatment of water in general.

The main reasons for this preference are the unique characteristics of the resin, which include:

- **Good chemical resistance:** PVC-U resins have excellent chemical resistance to most acids and alkalis, paraffin/aliphatic hydrocarbons and saline solutions. It is not recommended for the transport of polar organic compounds, including some types of chlorinated and aromatic solvents. PVC-U resins are also fully compatible with the transport of foodstuffs, demineralised water, potable water and unconditioned water, as provided for by current national and international standards.
- **Good thermal stability:** PVC-U resins have good thermal stability in the temperature range between 20°C and 50°C and are typically used in industrial and water supply applications, guaranteeing excellent mechanical strength, sufficient rigidity for the purpose, reduced thermal expansion coefficients and high factors of safety in service. PVC-U compounds are also resistant to combustion with a flash point of 399°C. The flame, in fact, only persists if the oxygen concentration is twice that of atmospheric or in the presence of a flame from an external source. Flash point: 399° C. Oxygen index: 45%. UL 94 class: V0.
Thanks to the reduced coefficient of thermal conductivity ($\lambda = 0,15 \text{ W/m } ^\circ\text{C}$ according to ASTM C177) the use of PVC-U resin for transporting hot fluids reduces heat loss and virtually eliminates condensation problems.
- **Good mechanical strength:** PVC-U resins are characterised by their low permeability to oxygen and reduced water absorption (0.1% at 23°C according to ASTM D 570). The thermal stability of the material leads to good impact resistance and the capacity to support service pressures of 4 - 6 - 10 - 16 bar at 20°C.
- **Resistance to ageing:** PVC-U resins have a high circumferential breaking strength (Minimum Required Strength MRS $\geq 25.0 \text{ MPa}$ at 20°C) and allow long installation lifetimes without showing any signs of significant physical-mechanical deterioration.

Density	
Test method	ISO 1183 - ASTM D792
Unit of measurement	g/cm ³
Value	1,38
Modulus of elasticity	
Test method	ISO 527
Unit of measurement	MPa = N/mm ²
Value	3200
Charpy impact strength at 23°C	
Test method	ASTM D256
Unit of measurement	KJ/m ²
Value	5-8
Ultimate elongation	
Test method	ISO 527
Unit of measurement	%
Value	50
Shore hardness	
Test method	ISO 868
Unit of measurement	Shore D
Value	80
Tensile strength	
Test method	ISO 527
Unit of measurement	MPa = N/mm ²
Value	50
VICAT softening point (B/50)	
Test method	ISO 306
Unit of measurement	°C
Value	76
Heat distortion temperature HDT (0.46 N/mm²)	
Test method	ASTM D648
Unit of measurement	°C
Value	86
Thermal conductivity at 23°C	
Test method	DIN 52612-1 - ASTM C177
Unit of measurement	W/(m °C)
Value	0,16
Coefficient of linear thermal expansion	
Test method	DIN 53752 - ASTM D696
Unit of measurement	m/(m °C)
Value	8 x 10 ⁻⁵
Limiting Oxygen Index	
Test method	ISO 4859-1 - ASTM D2863
Unit of measurement	%
Value	43

Reference standards

PVC-U

Production of the PVC-U lines is carried out according to the highest quality standards and in full compliance with the environmental restrictions set by the applicable laws in force and in accordance with **ISO 14001**.

All products are made in accordance with the quality guarantee system in compliance with **ISO 9001**.

- **BS 10**

Specification for flanges and bolts for pipes, valves and fittings

- **BS 3505**

Specification for PVC-U pressure pipes for cold water supplies

- **BS 4346-1**

Joints and fittings for use with solvent weld PVC-U pressure pipes

- **DIN 8061**

PVC-U pipes: General quality requirements and testing

- **DIN 8062**

PVC-U pipes - dimensions

- **DVS 2204 - DVS 2221**

Adhesive bonding of thermoplastic PVC-U pipes and fittings

- **EN 10226**

Pipe threads where pressure tight joints are made on the threads.

- **EN 1092-1**

Flanges and their joints - Circular flanges for pipes, valves and accessories - Part 1: PN designated steel flanges

- **EN 14728**

Imperfections in thermoplastic welds -classification

- **EN ISO 1452**

PVC-U pipes, fittings and valves for water supply systems

- **EN ISO 15493**

Plastic piping systems (Pipes, Fittings and Valves) in ABS, PVC-U, PVC-C for industrial applications

- **ISO 161-1**

Thermoplastics pipes for the conveyance of fluids -Nominal outside diameters and nominal pressures , metric series

- **ISO 228-1**

Fittings with threaded joints

- **ISO 7**

Fittings with pressure-tight threaded joints

- **ISO 727**

PVC-U pipes and fittings Dimensions and tolerances, metric series

- **ISO 9624**

Thermoplastic piping systems for fluids under pressure -flange adapters and loose backing flanges- Mating dimensions

- **UNI 11242**

Solvent welding of PVC-U and PVC-C pipes, fittings and valves

Approvals and quality marks



- **ACS France (Attestation de conformité Sanitaire)**
Suitability of PVC-U for drinking water



- **WRAS (Water regulations advisory scheme - UK)**
Suitability of PVC-U for transporting potable water



- **IIP N. 122 Istituto Italiano dei Plastici (Italian Plastics Institute)**
PVC-U fittings and pipes to standard UNI EN ISO 1452-3

Solvent welding

Instructions

Solvent welding, or cement jointing, is the longitudinal joining system for connecting rigid PVC-U pipes and fittings.

The "cementing" is carried out using adhesives/cements obtained by dissolving PVC-U polymer in a solvent mixture. This solvent liquefies the walls of the pipe and/or fitting, allowing the constituent material to chemically combine and be subsequently welded. Chemical welding allows permanent joints be achieved possessing chemical and mechanical strength characteristics identical to those of the pipes and fittings joined. The adhesives/solvent cements must be selected according to the type of thermoplastic resin to weld, in that the nature of the solvents vary, as does the weld material contained in them. It must be remembered, therefore, that all the solvent cements designed for joining thermoplastic pipes and fittings must be used to join pipes, fittings and valves of the same material.

Before starting any solvent welding operations, the efficiency and condition of the equipment used and the pieces to be assembled must be verified, in particular the uniformity, fluidity and expiry date of the solvent cement.

- 1) Cut the pipe perpendicular to its axis to obtain a clean square section, preferably using a wheeled pipe cutter designed specifically for thermoplastic pipes (fig. 1).
- 2) Chamfer the outer edges of the pipe in order to ensure that it enters the socket of the fitting at an angle of 15°. The chamfering operation must be carried out at all costs, otherwise the lack of chamfer can lead to the solvent being scraped off the surface of the fitting, thus compromising the effectiveness of the joint. The chamfering must be carried out using the appropriate chamfering tool (fig. 2).
- 3) Measure the depth of the socket of the fitting to the internal shoulder and mark the corresponding distance on the end of the pipe (fig. 3 and 4).

For more details, refer to the "Socket depth, cement and chamfer length" table.

- 4) Using a clean paper towel or applicator soaked in Cleaner-Primer, remove any traces of dirt or grease from the outer surface of the pipe for the entire cementing length. Repeat the same operation on the internal surface of the socket of the fitting: leaving the surfaces softened (fig. 5).

Leave the surfaces to dry for a few minutes before applying the solvent cement. Remember that, in addition to cleaning the joint surfaces, the Cleaner-Primer also performs the important role of softening and preparing the surface to receive the solvent, an operation that enables a perfect joint to be obtained.

- 5) Apply the solvent cement in a uniform manner longitudinally over both parts to be assembled (outer surface of the pipe and internal coupling surface of the fitting) using an applicator or suitably sized coarse brush.

For more detailed information, refer to the "Brush-applicator characteristics and dimensions" table.



Fig. 1



Fig. 2



Fig. 3



Fig. 4



Fig. 5

It is advisable to use an applicator/brush of dimension not less than half the diameter of the pipe. The solvent cement must be applied along the entire length of the joining surface of both the pipe and the fitting:

- for the entire joint length of the pipe previously marked on the outer surface (fig. 6)
- for the entire depth of the socket as far as the internal shoulder (fig.7)

6) Fully insert the pipe into the fitting immediately and without any rotation. Only after this operation will it be possible to slightly rotate both ends (max. 1/4 of a turn between pipe and fitting). This rotation movement will render the layer of applied solvent cement more uniform (fig. 8)

7) The pipe must be inserted in the fitting as soon and as quick as possible (after no more than 20-25 seconds is recommended). Depending on the external diameter of the pipe and, as a result, possible handling difficulties, the insertion of the pipe into the fitting must be carried out:

- manually by one person for external diameters < 90 mm.
- manually by two people for external diameters from d 90 to d < 160 mm.
- using mechanical pipe-pullers for external diameters > 160 mm.

8) Immediately after fully inserting the pipe in the fitting, apply pressure to the joined parts for a few seconds. Then use crepe paper or a clean cloth to remove any excess solvent cement from the outer surfaces, and from internal surfaces where possible (fig. 9).

9) Solvent cement drying: the joined parts must be left to stand in order to allow the solvent cement to set naturally without generating any unnecessary stress. The setting time depends on the amount of stress that the joint will be placed under.

In particular, the following minimum setting times must be respected according to the ambient temperature:

- before handling the joint:
 - from 5 to 10 minutes for ambient T. > 10°C
 - from 15 to 20 minutes for ambient T. < 10°C
- for repair joints on pipes of any size or pressure not subject to hydraulic testing:
 - 1 hour for each atm of applied pressure
- for joints in pipes and fittings of any diameter subject to pressure testing up to PN 16:
 - minimum 24 hours

The solvent cement setting times indicated are valid at ambient temperature (approx. 25°C.). For particular climatic conditions (humidity, temperature, etc...), we recommend you contact our technical services department and/or the solvent cement manufacturer for more information (fig. 10 and 11).



Fig. 6



Fig. 7



Fig.8



Fig.9

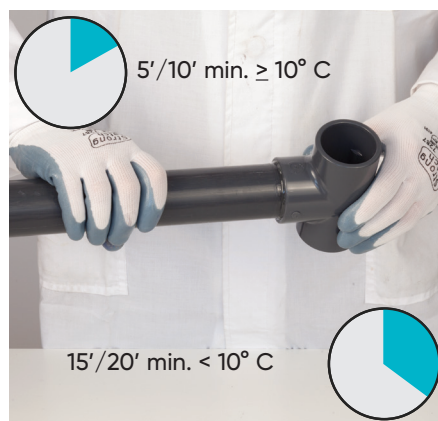

Fig.10

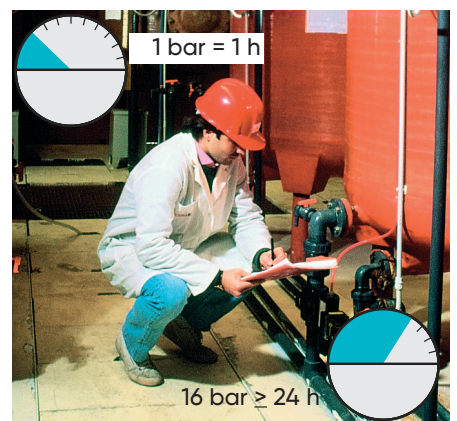
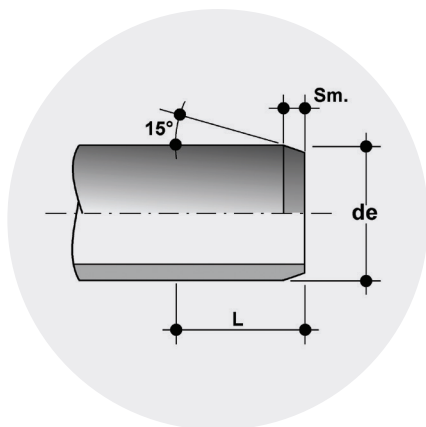

Fig.11



Socket depth, cement and chamfer length

External diameter		Cementing length L (mm)		Chamfer Sm (mm)
Metric series de (mm)	BS series (inches)	Metric series	BS series	
16	3/8"	14	14.5	
20	1/2"	16	16.5	1.5
25	3/4"	18,5	19.5	3
32	1"	22	22.5	3
40	1" 1/4	26	27	3
50	1" 1/2	31	30	3
63	2"	37,5	36	5
75	2" 1/2	43,5	43.5	5
90	3"	51	50.5	5
110	4"	61	63	5
125	-	68,5	-	5
140	5"	76	76	5
160	6"	86	90	5
180	-	96	-	5÷6
200	-	106	-	5÷6
225	8"	118,5	115.5	5÷6
250	-	131	-	5÷6
280	10"	146	142.5	5÷6
315	12"	163,5	168	5÷6

Characteristics and dimensions of brushes-applicators

External diameter		Type and dimensions of Brush or Applicator
de (mm)	de (inch)	
16 - 25	3/8" - 3/4"	Round (8 ÷ 10 mm)
32 - 63	1" - 2"	Round (20 ÷ 25 mm)
75 - 160	2" 1/2 - 6"	Rectangular / round (45 ÷ 50 mm)
>160	>6"	Rectangular / cylindrical (45 ÷ 50 mm)
>160 - 315	>6" - 12"	Rectangular / cylindrical (60 ÷ 65 mm)

Warnings

- In the case where the external diameter of the pipe and the internal diameter of the fitting are at opposite extremes of their tolerance values, the dry pipe cannot be inserted in the dry socket of the fitting. Insertion will only be possible after having applied the Cleaner and Solvent Cement to both parts to be joined.
- The solvent cement is manufactured from the same PVC resin used for the production of the pipes, fittings and valves. Unless otherwise specified, the solvent cement used on the surfaces to join must also be usable with the following tolerances:
 - maximum interference 0.2 mm,
 - maximum clearance 0.6 mm.
- When using the Cleaner and Solvent Cement, the following precautions should be adopted:
 - use gloves and safety glasses to protect hands and eyes.
 - use the Cleaner and Solvent Cement in a working environment with sufficient ventilation to avoid the formation of pockets of air containing concentrations of evaporated solvent, which can irritate the respiratory tract and eyes,
 - due to the volatile nature of the solvents in the cleaner and cement, the containers must be closed immediately after use,
 - Solvents in the gaseous phase tend to form flammable mixtures. Therefore, remove any ignition sources such as welding operations, accumulation of electrostatic charges, etc. from the work area, and do not smoke. In all cases, it is advisable to adhere strictly to the solvent cement manufacturer's instructions written on the packaging,
 - In order to prevent a deterioration in the performance of the cleaner and solvent cement, the joining operations should be carried out within an ambient temperature range of between + 5 and + 40° C.
- The amount of solvent cement used on the joints depends on a number of factors (environmental conditions, pipe size, cement viscosity, operator experience, etc.) which are often difficult to quantify. In this respect, Table "Rigid PVC-U pipes and fittings. Theoretical solvent cement consumption" reports the approximate quantities of cement normally used for joining various diameter pipes and fittings.
- After having completed all the joints and prior to putting the lines into service, make sure that the insides of the pipes and fittings are completely free of any solvent traces/ vapours. This will prevent contamination of the fluids conveyed.
- Table "Most common defects" reports the most common types of defect found if the correct solvent welding procedure is not followed.

Rigid PVC-U pipes and fittings theoretical solvent cement consumption

Pipe/Fitting diameter		Number of joints per kg of solvent cement
d (mm)	d (inches)	
16	3/8"	550
20	1/2"	500
25	3/4"	450
32	1"	400
40	1" 1/4	300
50	1" 1/2	200
63	2"	140
75	2" 1/2	90
90	3"	60
110	4"	40
125	-	30
140	5"	25
160	6"	15
180	-	12
200	-	10
225	8"	6
250	-	4
280	10"	2
315	12"	2

Most common defects

Solvent cement too fluid (incorrect diluent addition)	
Immediate effect	Cementing failure
Consequence	Joint separation or leaks from between the pipe and fitting
Excess solvent cement	
Immediate effect	Internal and external runs beyond the joint zone
Consequence	Weakening of the outer surface of the joint area and formation of bubbles with micro-cracks/sources of fracture in the base material
Excessively dense solvent cement due to evaporated solvent	
Immediate effect	Cementing failure
Consequence	Joint separation or leaks from between the pipe and fitting. Possible surface cracks triggering cracks in the base material
Insufficient and/or incorrect distribution of solvent cement	
Immediate effect	Cementing failure or local weakness
Consequence	Joint separation or leaks from between the pipe and fitting
Incorrect pipe insertion (incomplete, excessive, misaligned)	
Immediate effect	Imperfect joint
Consequence	Transmission of mechanical stresses from the pipe to the fitting and/or leaks from the joint
Impurities and/or humidity on the surfaces of the parts to join	
Immediate effect	Imperfect joint
Consequence	Joint separation or leaks (fluid seepage) from between the pipe and fitting

Installation instructions for threaded joints

To guarantee the hydraulic seal of the joint on fittings and valves with a threaded female end, we recommend you perform the following operations:

1. Start winding some PTFE sealing tape on the outside of the threaded male end, taking care not to obstruct the through-hole on the pipe, fitting or valve (fig. 1);
2. Complete the first winding layer by winding the tape clockwise until you reach the root of the thread. Remember to keep the tape taut throughout the entire process (fig. 2);
3. Press on the tips of the thread to make sure the tape adheres fully to the support clip;
4. Increase the thickness of the PTFE layer by continuing to apply the taut tape and winding it clockwise until you achieve the optimal level (fig. 3);
5. Connect the previously sealed male end to the female end and proceed manually by screwing the two elements;
6. Make sure the layer of PTFE is not removed during screwing, as this would compromise the hydraulic seal of the joint;
7. Complete screwing the two ends exploiting the entire length of the thread with the aid of a strap wrench or similar tool;
8. Avoid tightening the elements too much, as this could damage the threads or cause stress to the elements themselves.

Recommendations

For correct installation, we recommend you only use sealing tape in non-sintered PTFE. Under all circumstances avoid using materials such as hemp, lint or paints usually implemented for the hydraulic seal on metal threads.

Warnings

Avoid using threaded joints in the following cases:

- highly critical applications, such as for conveying chemically aggressive or toxic fluids,
- in the presence of medium or high pressures. In this case, we recommend the use of solvent welding joints, hot welding joints or flanged joints,
- systems subject to mechanical and/or thermal stresses such as water hammers, strong variations in temperature, bends, misalignments and cross tensions which could cause the threaded joint to break prematurely,
- coupling of elements with excessive distance from one another.



Fig. 1

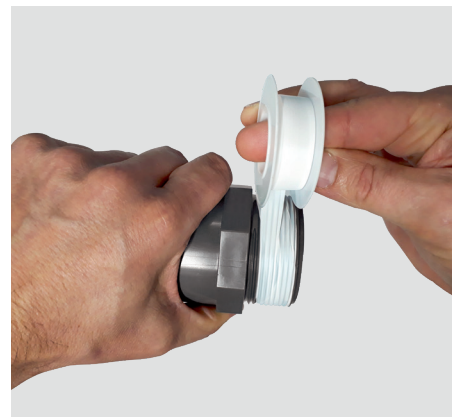
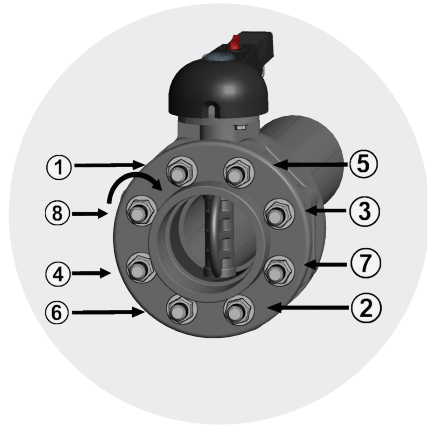

Fig. 2



Fig. 3

Installation instructions for flanged Joints



To guarantee the correct installation of flanged elements, we recommend you perform the following operations:

1. insert the possible backing ring onto the pipe, before proceeding with the installation of the stub;
2. in the event of a fixed flange, check the drilling is correctly aligned with the counter flange;
3. check that the position of the counter flange takes into account the overall dimensions of the face to face distance of the components;
4. insert the flat gasket between the stubs (this step is not necessary for butterfly valves), making sure the sealing surfaces of the flanges to be welded have not been separated by an excessive distance, since this would cause it to compress;
5. proceed with solvent welding or welding of the fixed flanges or stub (in the case of backing rings) following the welding or solvent welding instructions provided by FIP;
6. insert all the bolts, washers and nuts;
7. once the cooling time is up, proceed with tightening the bolts in a "cross-wise" order (fig.1);
8. complete the bolt tightening process using a torque wrench until the tightening torque values shown in the table are reached.

Tightening torque

Tightening torques for nuts and bolts to achieve the seal with flanges in PVC-U or PVC-C with gaskets in EPDM/FKM/NBR during the pressure test (1.5 x NP and water at 20°C),

DN	40	50	65	80	100	125	150	200	250	300	350	400
Nm	9	12	15	18	20	35	40	55	70	70	75	75

Please note that:









- the use of flanges in coated metal or fibreglass may allow the application of higher tightening torques, provided these do not exceed the elastoplastic limit of the material,
- the use of different elastomeric seal materials from those listed in the previous table may require slightly higher tightening torques,
- FIP always recommends the use of suitably sized washers for any bolt used in the coupling flange.

Minimum length of bolts

For flanged butterfly valves	
DN	Lmin
40	M 16x150
50	M 16x150
65	M 16x170
80	M 16x180
100	M 16x180
125	M 16x210
150	M 20x240
200	M 20x260
250	M 20x310
300	M 20x340
350	M 20x360
400	M 24x420

For flanged joints on pipes using backing rings		
d	DN	L min
20	15	M 12x70
25	20	M 12x70
32	25	M 12x70
40	32	M 16x85
50	40	M 16x85
63	50	M 16x95
75	65	M 16x95
90	80	M 16x105
110	100	M 16x105
125	125	M 16x115
140	125	M 16x120
160	150	M 20x135
200	200	M 20x140
225	200	M 20x140
250	250	M 20x150
280	250	M 20x160
315	300	M 20x180
355	350	M 20x180
400	400	M 22x180

Main properties

Properties of PVC-U		Benefits
Thermal resistance		<ul style="list-style-type: none"> • Service range 0–60 °C (see pressure/temperature regression curves)
Low surface roughness		<ul style="list-style-type: none"> • High flow coefficients (extremely smooth internal walls) • Pressure drop constant over time • Low risk of stoppages due to scaling • Reduced transfer of material to the transported fluid
Chemical resistance		<ul style="list-style-type: none"> • Good chemical resistance for conveying acids and alkalis, paraffin/aliphatic hydrocarbons and saline solutions.
Abrasion resistance		<ul style="list-style-type: none"> • Extremely low operating costs due to its long service life
Insulating		<ul style="list-style-type: none"> • Non-conductive (immune to galvanic corrosion) • No condensation problems • Minimum heat loss
Linear thermal expansion coefficients		<ul style="list-style-type: none"> • Reduced need for supports and expansion joints, resulting in considerable advantages in terms of plant design
Easy to join (solvent weld sockets)		<ul style="list-style-type: none"> • Reduced installation costs thanks to the “solvent weld” joint effected using a suitable solvent cement
Fire behaviour		<ul style="list-style-type: none"> • Good resistance to combustion also due to the presence of self-extinguishing chlorine
Good mechanical resistance		<ul style="list-style-type: none"> • PVC-U satisfies the need to provide adequate mechanical strength and complies with the requirements of industrial plant design

PVC PRESSURE FITTINGS

PVC (polyvinyl chloride) fittings for use in pressurised Irrigation Systems, water adduction, chemical installations and for water treatment in general.

PVC PRESSURE FITTINGS

Technical specifications	
Size range	Metric series: d 12 ÷ d 315 mm Threaded series: R 3/8" ÷ R 4" Transition series: d 16 x 3/8" ÷ d 110 x 4" Imperial BS Series: d 1/2" ÷ d 6" - BS Solvent welding range - BS Transition series for solvent welding/Threaded BSP
Nominal pressure	Metric series: PN 16 with water at 20 °C up to d 160 mm, PN 10 from d 180 to d 315 Threaded series: PN 16 with water at 20 °C Imperial BS Series: Class E with water at 20°C up to d 4", Class D up to 6" BS/BSP transition fittings: Class E up to 2", Class D from 2"1/2 to 4"
Temperature range	0 °C ÷ 60 °C
Reference standards	Metric series: ISO 727, EN ISO 1452-3, EN ISO 15493, BS 4346-1, UNI EN 10226-1 Threaded and transition series: ISO 7, ISO 228-1
Fitting material	PVC-U
Seal material	Gaskets in EPDM, on request FKM Reinforcing rings (TM3, GM3, MM3, RM3) in stainless steel AISI 430

TECHNICAL DATA

PRESSURE VARIATION ACCORDING TO TEMPERATURE

For water and non-hazardous fluids with regard to which the material is classified as CHEMICALLY RESISTANT. In other cases, a reduction of the nominal pressure PN is required (25 years with safety factor).

Class E (15 bar)

Class D (12 bar)

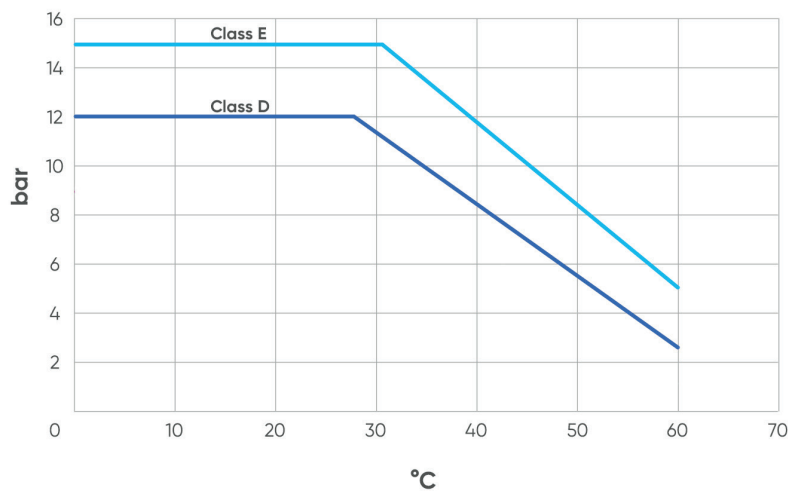

METRIC SERIES

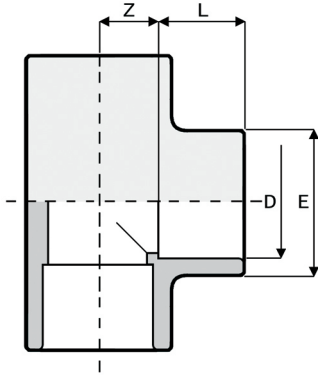

T11
90° Tee with solvent weld sockets

D	PN	L	Z	E	g	Code
16	16	14	9	23	13	1RT116000
20	16	16	11	27	22	1RT1120000
25	16	19	14	33	42	1RT1125000
32	16	22	18	40	66	1RT1132000
40	16	26	22	49	99	1RT1140000
50	16	31	26	61	162	1RT1150000
63	16	38	33	75	286	1RT1163000
75	16	44	39	80	506	1RT1175000
90	16	51	47	106	795	1RT1190000
110	16	61	61	128	1400	1RT111000
125	16	69	66	146	2020	1RT113000NL
140	16	76	72	163	2740	1RT115000
160	16	86	82	186	4042	1RT117000
200	10	106	102	230	6960	1RT1121000
225	10	119	115	258	9600	1RT1123000
250	10	131	128	286	13250	1RT1126000
280	10	146	144	319	17840	1RT1128000
315	10	164	162	360	25300	1RT1133000

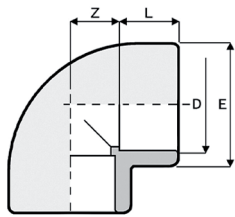

Fig. A

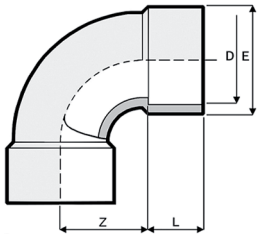
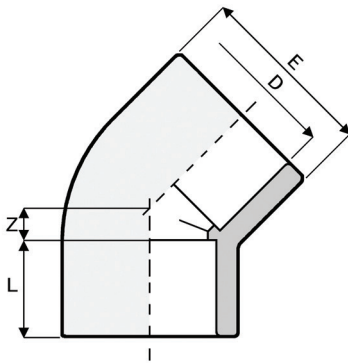

Fig. B

GO1

90° elbow with solvent weld sockets

D	PN	L	Z	E	g	Fig.	Code
16	16	14	9	23	14	A	1RGO116000
20	16	16	12	26	15	A	1RGO120000NL
25	16	19	14	34	35	A	1RGO125000
32	16	22	17	39	38	A	1RGO132000
40	16	26	21	51	95	A	1RGO140000
50	16	31	26	59	114	A	1RGO150000
63	16	38	33	75	197	A	1RGO163000
75	16	44	39	89	402	A	1RGO175000
90	16	51	47	106	600	A	1RGO190000
110	16	61	57	129	1020	A	1RGO111000
125	16	69	66	146	1385	A	1RGO113000
140	16	76	72	163	2125	A	1RGO115000
160	16	86	82	186	2920	A	1RGO117000
200	10	106	102	230	5400	A	1RGO121000
225	10	119	115	258	7550	A	1RGO123000
250	10	131	188	287	12480	B	1RGO126000
280	10	147	210	325	17000	B	1RGO128000
315	10	164	236	359	23370	B	1RGO133000



GY1

45° elbow with solvent weld sockets

D	PN	L	Z	E	g	Code
20	16	16	5	28	20	1RGY120000
25	16	19	6	34	25	1RGY125000
32	16	22	8	42	45	1RGY132000
40	16	26	10	51	75	1RGY140000
50	16	31	12	61	117	1RGY150000
63	16	38	14	75	230	1RGY163000
75	16	44	17	90	320	1RGY175000NL
90	16	51	21	107	550	1RGY190000NL
110	16	61	24	129	835	1RGY111000
125	16	69	27	145	1085	1RGY113000
140	16	76	31	163	1620	1RGY115000
160	16	86	35	186	2265	1RGY117000
200	10	108	48	230	4500	1RGY121000
225	10	121	55	260	6400	1RGY123000NL
250	10	131	58	286	7700	1RGY126000
280	10	146	62	320	10460	1RGY128000
315	10	164	66	359	15500	1RGY133000

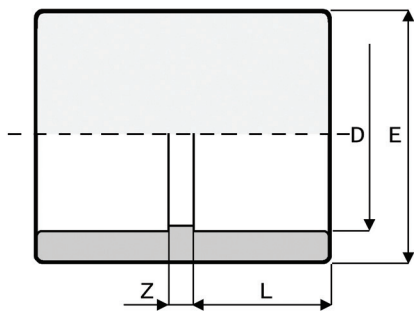

MA1
Solvent weld double socket

D	PN	L	Z	E	g	Code
16	16	14	3	21	7	1RMA16000NL
20	16	16	3	28	15	1RMA120000
25	16	19	3	34	20	1RMA125000
32	16	22	3	42	30	1RMA132000
40	16	26	3	51	60	1RMA140000
50	16	31	3	58	64	1RMA150000
63	16	38	3	75	140	1RMA163000
75	16	44	3	90	250	1RMA175000NL
90	16	51	4	108	415	1RMA190000NL
110	16	61	8	131	715	1RMA11000NL
125	16	69	7	148	960	1RMA113000NL
140	16	76	8	164	1240	1RMA115000NL
160	16	86	8	182	1380	1RMA117000
200	10	106	11	232	3050	1RMA121000NL
225	10	119	11	260	4600	1RMA123000NL
250	10	131	10	286	5760	1RMA126000
280	10	146	10	320	7630	1RMA128000
315	10	164	12	355	9780	1RMA133000

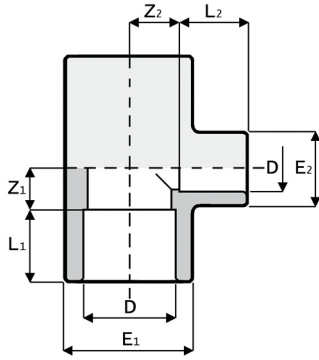

TR1

90° reducing tee with reduced branch and solvent weld sockets

D x D	PN	L ₁	L ₂	Z ₁	Z ₂	E ₁	E ₂	g	Code
20 x 16	16	16	14	11	11	28	23	30	1RTR120A00
25 x 16	16	19	14	14	14	34	23	45	1RTR125A00
25 x 20	16	19	16	14	14	34	28	45	1RTR125B00
32 x 16	16	22	14	17	17	42	23	65	1RTR132A00
32 x 20	16	22	16	17	17	41	28	60	1RTR132B00NL
32 x 25	16	22	19	17	17	42	34	65	1RTR132C00
40 x 16	16	26	14	21	21	51	23	105	1RTR140A00
40 x 20	16	26	16	21	21	51	28	110	1RTR140B00
40 x 25	16	26	19	21	21	51	34	110	1RTR140C00
40 x 32	16	26	22	21	21	51	42	110	1RTR140D00
50 x 20	16	31	16	26	26	61	29	180	1RTR150B00
50 x 25	16	31	19	26	26	61	35	182	1RTR150C00
50 x 32	16	31	22	26	26	61	42	183	1RTR150D00
50 x 40	16	31	26	26	26	61	51	184	1RTR150E00
63 x 20	16	38	16	33	33	75	28	275	1RTR163B00
63 x 25	16	38	19	33	33	75	36	304	1RTR163C00
63 x 32	16	38	22	33	33	75	43	306	1RTR163D00
63 x 40	16	38	26	33	33	75	52	313	1RTR163E00
63 x 50	16	38	31	33	33	75	62	325	1RTR163F00
75 x 32	16	44	22	40	40	91	41	530	1RTR175D00NL
75 x 40	16	44	26	40	40	91	50	540	1RTR175E00NL
75 x 50	16	44	31	40	40	91	61	550	1RTR175F00NL
75 x 63	16	44	38	40	40	91	76	580	1RTR175G00NL
90 x 40	16	51	26	48	48	109	50	870	1RTR190E00NL
90 x 50	16	51	31	48	48	109	61	880	1RTR190F00NL
90 x 63	16	51	38	48	48	109	76	900	1RTR190G00NL
90 x 75	16	51	44	48	48	109	91	940	1RTR190H00NL
110 x 50	16	61	31	61	61	133	61	1580	1RTR111F00NL
110 x 63	16	61	38	61	61	133	76	1590	1RTR111G00NL
110 x 75	16	61	44	61	61	133	91	1610	1RTR111H00NL
110 x 90	16	61	51	61	61	133	109	1640	1RTR111I00NL
160 x 110	16	86	61	82	57	187	131	3744	1RTR117L00

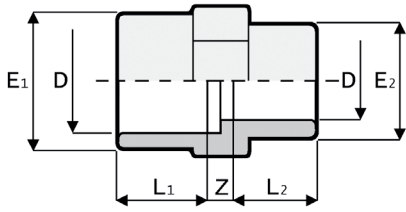

Fig. A

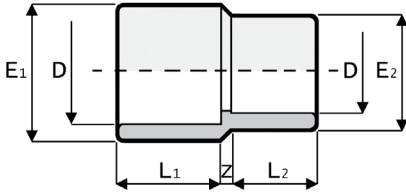

Fig. B

MR1

Reducer with solvent weld double socket

D x D	PN	L ₁	L ₂	Z	E ₁	E ₂	Fig.	g	Code
20 x 16	16	16	14	6	28	23	B	10	1RMR120A00
25 x 20	16	19	16	6	34	28	B	13	1RMR125B00
32 x 25	16	22	19	6	42	34	B	37	1RMR132C00
40 x 32	16	26	22	6	51	42	B	55	1RMR140D00
50 x 40	16	31	26	6	61	51	B	80	1RMR150E00
63 x 50	16	38	31	6	75	61	B	130	1RMR163F00
75 x 63	16	44	38	4	89	75	A	210	1RMR175G00
90 x 75	16	51	44	5	106	89	A	370	1RMR190H00
110 x 90	16	61	51	6	129	106	A	528	1RMR111I00
125 x 110	16	69	61	24	145	129	B	809	1RMR113L00
140 x 110	16	76	81	25	160	129	B	1166	1RMR115L00

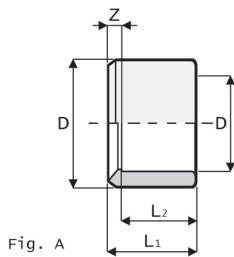

Fig. A

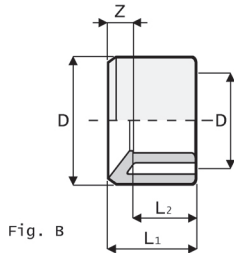

Fig. B

RC1

Reducing bush with solvent weld spigot and solvent weld socket

D x D	PN	L ₁	L ₂	Z	Fig.	g	Code
25 x 16	16	19	14	5	B	10	1RRC125A00
25 x 20	16	19	16	3	A	5	1RRC125B00NL
32 x 16	16	22	14	8	B	15	1RRC132A00
32 x 20	16	22	16	6	B	18	1RRC132B00
32 x 25	16	22	19	3	A	10	1RRC132C00NL

D x D	PN	L ₁	L ₂	Z	Fig.	g	Code
40 x 20	16	26	15	9	B	25	1RRC140B00NL
40 x 25	16	26	19	7	B	24	1RRC140C00NL
40 x 32	16	26	22	4	A	15	1RRC140D00
50 x 20	16	31	16	15	B	50	1RRC150B00
50 x 25	16	31	19	12	B	45	1RRC150C00
50 x 32	16	31	22	8	B	35	1RRC150D00NL
50 x 40	16	31	26	5	A	32	1RRC150E00NL
63 x 32	16	38	22	16	B	73	1RRC163D00NL
63 x 40	16	38	25	11	B	75	1RRC163E00NL
63 x 50	16	38	31	7	A	65	1RRC163F00
75 x 40	16	44	26	18	B	120	1RRC175E00
75 x 50	16	44	31	13	B	120	1RRC175F00NL
75 x 63	16	44	38	6	A	85	1RRC175G00NL
90 x 50	16	51	31	20	B	220	1RRC190F00
90 x 63	16	51	38	13	B	205	1RRC190G00
90 x 75	16	51	44	7	A	150	1RRC190H00
110 x 63	16	61	38	23	B	375	1RRC111G00
110 x 75	16	61	44	17	B	380	1RRC111H00
110 x 90	16	61	51	9	A	280	1RRC111I00
125 x 75	16	69	44	25	B	440	1RRC113H00
125 x 90	16	69	51	18	B	455	1RRC113I00
125 x 110	16	69	61	8	A	300	1RRC113L00
140 x 90	16	76	51	25	B	730	1RRC115I00NL
140 x 110	16	76	59	17	A	645	1RRC115L00NL
140 x 125	16	76	66	9	A	350	1RRC115M00NL
160 x 90	16	86	51	35	B	1040	1RRC117I00NL
160 x 110	16	86	60	24	B	945	1RRC117L00NL
160 x 125	16	86	69	17	B	1840	1RRC117M00
160 x 140	16	86	76	10	A	565	1RRC117N00NL
200 x 160	10	106	86	20	B	1310	1RRC121O00
225 x 160	10	119	86	33	B	1840	1RRC123O00
225 x 200	10	119	106	13	A	1380	1RRC123P00NL
250 x 160	10	119	106	13	A	1196	1RRC126O00
280 x 225	10	147	119	27	B	4300	1RRC128Q00
315 x 200	10	165	106	58	B	8650	1RRC133P00
315 x 225	10	165	119	45	B	8100	1RRC133Q00
315 x 250	10	165	131	33	B	5080	1RRC133R00

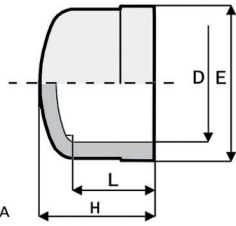

Fig. A

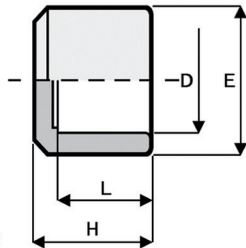
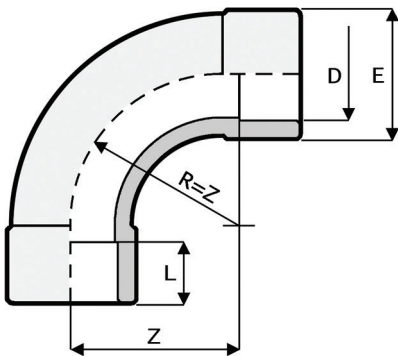

Fig. B

CA1

End cap with solvent weld socket

D	PN	L	H	E	Fig.	g	Code
16	16	15	17	21	A	4	1RCA116000NL
20	16	16	23	28	A	9	1RCA120000NL
25	16	19	27	34	A	15	1RCA125000NL
32	16	22	31	41	A	25	1RCA132000NL
40	16	26	36	51	A	40	1RCA140000NL
50	16	31	43	62	A	60	1RCA150000NL
63	16	38	51	77	A	110	1RCA163000NL
75	16	44	59	91	A	190	1RCA175000NL
90	16	51	69	110	A	330	1RCA190000NL
110	16	61	85	133	A	575	1RCA111000NL
125	16	69	99	147	B	900	1RCA113000NL
140	16	76	108	164	B	1100	1RCA115000NL
160	16	86	123	182	B	1080	1RCA117000



CU1

90° long radius bend (R=2d) with solvent weld sockets

D	PN	L	Z	E	g	Code
20	16	16	40	27	35	1RCU120000
25	16	19	50	33	56	1RCU125000
32	16	22	65	41	96	1RCU132000
40	16	26	80	50	170	1RCU140000
50	16	31	100	61	310	1RCU150000
63	16	38	126	77	510	1RCU163000
75	16	44	150	94	995	1RCU175000
90	16	51	180	113	1765	1RCU190000
110	16	61	220	137	2805	1RCU111000

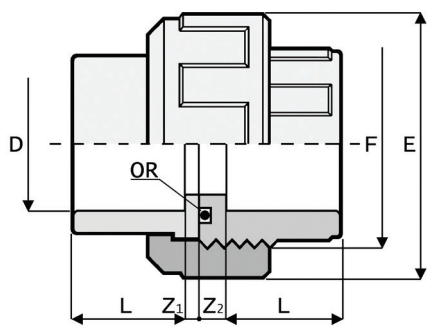

BO1

Union with solvent weld socket and O-Ring in EPDM (FKM on request)

D	PN	L	Z ₁	Z ₂	F	E	O-R	g	Code
16	16	11	3	10	3/4"	31	3062	30	1RBO116000
20	16	16	3	10	1"	42	4081	42	1RBO120000
25	16	19	3	10	1 1/4"	52	4112	70	1RBO125000
32	16	22	3	10	1 1/2"	59	4131	97	1RBO132000
40	16	26	3	12	2"	72	6162	156	1RBO140000
50	16	31	3	14	2 1/4"	79	6187	216	1RBO150000
63	16	38	3	18	2 3/4"	96	6237	368	1RBO163000
75	16	44	3	18	3 1/2"	120	6300	590	1RBO175000L
90	16	51	5	18	4"	135	6362	770	1RBO190000L
110	16	61	5	18	5"	163	6300	1300	1RBO11000L

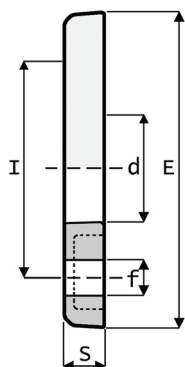

FL1

Loose flange

D	PN	DN	d	E	S	I	f	n° drill	g	Bolts	Code
20	16	15	28	96	11	65	14	4	70	M12 x 70	1RFL120000
25	16	20	34	107	12	75	14	4	85	M12 x 70	1RFL125000
32	16	25	42	117	14	85	14	4	120	M12 x 70	1RFL132000
40	16	32	51	143	15	100	18	4	190	M16 x 85	1RFL140000
50	16	40	62	153	16	110	18	4	225	M16 x 85	1RFL150000
63	16	50	78	168	18	125	18	4	280	M16 x 85	1RFL163000NL
75	16	65	92	188	19	145	18	4	390	M16 x 95	1RFL175000
90	16	80	110	203	20	160	18	8	460	M16 x 100	1RFL190000
110	16	100	132	222	22	180	18	8	515	M16 x 100	1RFL111000
125	16	125	149	250	26	210	18	8	950	M16 x 100	1RFL112500
140	16	125	166	251	26	210	18	8	813	M16 x 110	1RFL115000NL
160	16	150	189	290	29	240	22	8	915	M20 x 120	1RFL117000NL
200	10	200	235	340	30	295	22	8	1210	M20 x 120	1RFL121000NL
225	10	200	252	340	30	295	22	8	1090	M20 x 140	1RFL123000NL
250	10	250	278	396	34	350	22	12	1790	M40 x 140	1RFL126000NL
280	10	250	309	396	35	350	22	12	1880	M20 x 160	1RFL128000
315	10	300	349	465	40	400	22	12	3050	M20 x 180	1RFL133000

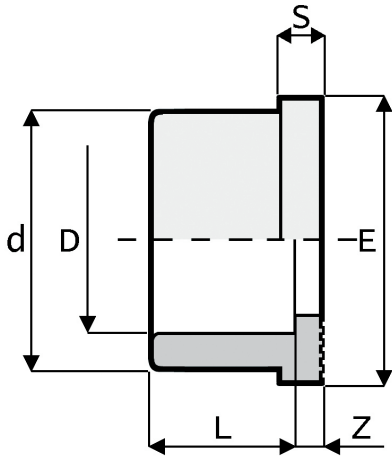

QR1

Serrated face stub PN 10/16 with solvent weld socket

D	PN	L	Z	d	S	E	g	Code
20	16	16	3	27	6	34	10	1RQR120000
25	16	19	3	33	7	41	16	1RQR125000
32	16	22	3	41	7	50	26	1RQR132000
40	16	26	3	50	8	61	42	1RQR140000
50	16	31	4	61	8	73	63	1RQR150000
63	16	38	4	76	9	90	112	1RQR163000
75	16	44	3	90	10	106	169	1RQR175000
90	16	51	5	108	11	125	273	1RQR190000
110	16	61	5	131	12	150	439	1RQR111000
125	16	69	5	147	13	168	750	1RQR113000NL
140	16	76	5	165	14	188	790	1RQR115000NL
160	16	86	4	188	16	212	1112	1RQR117000
200	10	106	5	230	18	254	1840	1RQR121000NL
225	10	119	5	245	25	273	1750	1RQR123000NL
250	10	131	8	270	20	306	2140	1RQR126000NL
280	10	147	14	307	32	327	3650	1RQR128000
315	10	165	13	346	32	375	4791	1RQR133000

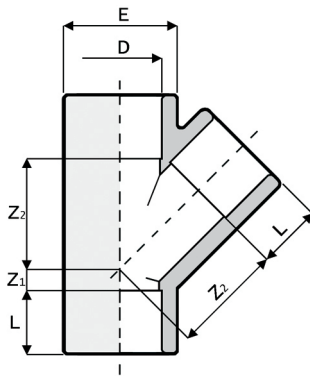

TY1

45° Tee with solvent weld sockets

D	PN	L	Z ₁	Z ₂	E	g	Code
20	16	16	7	30	27	39	1RTY120000
25	16	19	7	35	33	62	1RTY125000
32	16	22	9	44	41	110	1RTY132000
40	16	26	11	55	50	190	1RTY140000
50	16	31	12	68	63	326	1RTY150000
63	16	38	15	85	78	584	1RTY163000

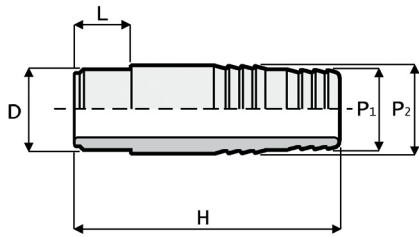

PO1

Hose adaptor with solvent weld spigot

DxP1xP2	PN	L	H	g	Code
16 x 18 x 16	16	14	60	12	1RPO116000
20 x 22 x 20	16	16	67	17	1RPO120000
25 x 27 x 25	16	19	81	26	1RPO125000
32 x 32 x 30	16	22	97	40	1RPO132000
40 x 42 x 40	16	26	104	78	1RPO140000
50 x 52 x 50	16	31	111	113	1RPO150000
63 x 64 x 60	16	38	123	170	1RPO163000

THREADED SERIES

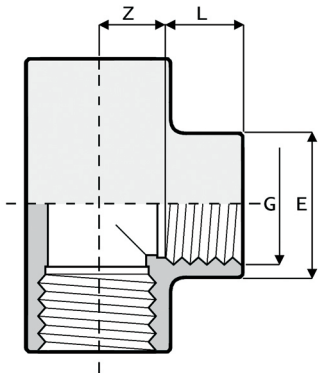

T12

90° Tee with BSP threaded female ends

G	PN	L	Z	E	g	Code
3/8"	16	11	12	23	37	1RTI216000
1/2"	16	15	13	28	30	1RTI220000
3/4"	16	16	17	35	55	1RTI225000
1"	16	19	20	43	80	1RTI232000
1 1/4"	16	21	27	50	117	1RTI240000NL
1 1/2"	16	21	37	61	260	1RTI250000NL
2"	16	26	46	76	465	1RTI263000NL
2 1/2"	16	30	55	91	640	1RTI275000NL
3"	16	33	66	109	1135	1RTI290000NL

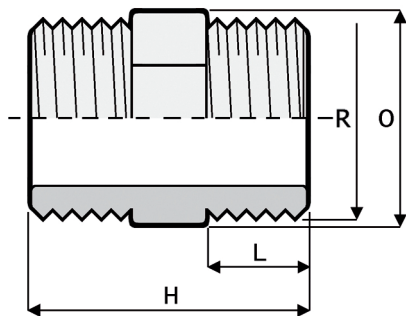

N12

Barrel nipple with BSP threaded male ends

R	PN	L	H	O	g	Code
3/8"	16	11	33	22	5	1RNI216000
1/2"	16	15	42	24	10	1RNI220000
3/4"	16	16	44	30	20	1RNI225000
1"	16	19	50	36	30	1RNI232000
1 1/4"	16	21	58	46	45	1RNI240000
1 1/2"	16	21	58	50	63	1RNI250000
2"	16	26	66	65	105	1RNI263000
2 1/2"	16	30	78	80	175	1RNI275000
3"	16	33	85	95	245	1RNI290000
4"	16	39	96	120	348	1RNI211000

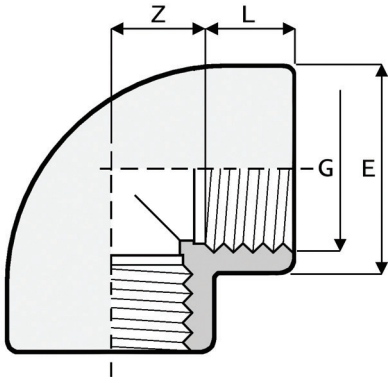

GO2

90° elbow with BSP threaded female ends

G	PN	L	Z	E	g	Code
3/8"	16	11	12	23	27	1RGO216000
1/2"	16	15	13	28	25	1RGO220000
3/4"	16	16	17	35	40	1RGO225000
1"	16	19	20	43	65	1RGO232000
1 1/4"	16	21	26	51	100	1RGO240000
1 1/2"	16	21	36	61	190	1RGO250000
2"	16	26	45	76	340	1RGO263000
2 1/2"	16	30	53	89	455	1RGO275000
3"	16	33	65	106	545	1RGO290000
4"	16	39	79	129	1030	1RGO211000

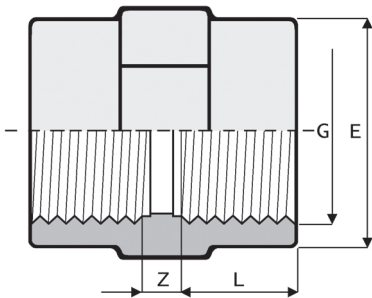

MA2

Double socket with BSP threaded female ends

G	PN	L	Z	E	g	Code
3/8"	16	11	8	23	10	1RMA216000
1/2"	16	15	7	28	17	1RMA220000
3/4"	16	16	8	35	26	1RMA225000
1"	16	19	9	43	42	1RMA232000
1 1/4"	16	21	11	51	53	1RMA240000
1 1/2"	16	21	17	61	108	1RMA250000
2"	16	26	19	76	190	1RMA263000
2 1/2"	16	30	9	89	215	1RMA275000
3"	16	33	10	106	305	1RMA290000

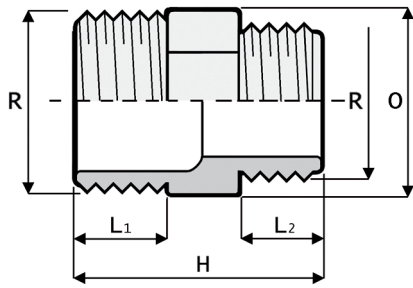

NR2

Reducing barrel nipple with BSP threaded male ends

R x R	PN	L ₁	L ₂	H	O	g	Code
3/4" x 1/2"	16	16	15	43	30	15	1RNR225B00
1" x 3/4"	16	19	16	47	36	25	1RNR232C00
1 1/4 x 1"	16	21	19	56	46	40	1RNR240D00
1 1/2 x 1 1/4	16	21	21	58	50	60	1RNR250E00
2" x 1 1/2	16	26	21	62	65	90	1RNR263F00
2 1/2 x 2"	16	30	26	72	80	155	1RNR275G00
3" x 2 1/2	16	33	30	82	95	240	1RNR290H00
4" x 3"	16	39	33	90	120	357	1RNR211I00

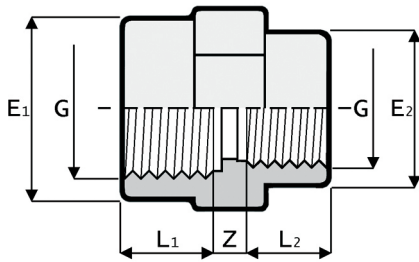

MR2

Reducing socket with BSP threaded female ends

G x G	PN	L ₁	L ₂	Z	E ₁	E ₂	g	Code
1/2" x 3/8"	16	15	11	6	28	23	7	1RMR220A00
3/4" x 1/2"	16	16	15	7	34	28	25	1RMR225B00
1" x 3/4"	16	19	16	7	42	34	40	1RMR232C00
1 1/4 x 1"	16	21	19	8	51	42	34	1RMR240D00
1 1/2 x 1 1/4	16	21	21	8	58	51	79	1RMR250E00
2" x 1 1/2	16	26	21	8	72	58	130	1RMR263F00
2 1/2 x 2"	16	30	25	8	89	72	178	1RMR275G00
3" x 2 1/2	16	33	30	9	103	89	226	1RMR290H00
4" x 3"	16	39	33	10	130	103	515	1RMR211I00

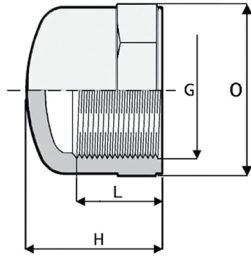

CA2

End cap with BSP threaded female end

G	PN	L	H	E	g	Code
1/2"	16	15	25	28	10	1RCA220000
3/4"	16	16	27	34	15	1RCA225000
1"	16	19	31	42	27	1RCA232000
1 1/4"	16	21	35	51	40	1RCA240000
1 1/2"	16	21	36	58	53	1RCA250000
2"	16	26	42	71	85	1RCA263000
3"	16	33	55	109	310	1RCA290000NL

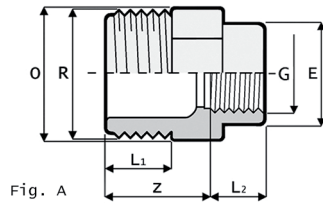

Fig. A

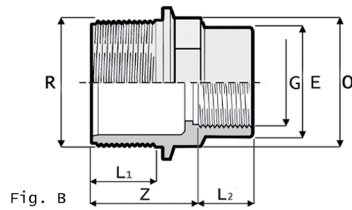
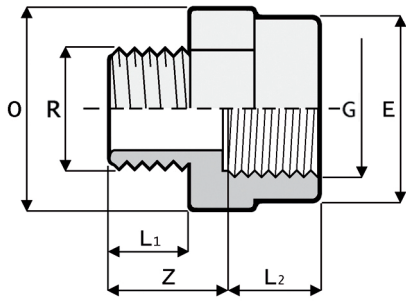

Fig. B

RI2

Reducer with BSP threaded male end and BSP threaded female end

R x G	PN	L ₁	L ₂	Z	E	O	g	Fig.	Code
1/2" x 3/8"	16	15	11	24	23	24	21	A	1RRI220A00
3/4" x 3/8"	16	16	11	20	34	28	15	B	1RRI225A00NL
3/4" x 1/2"	16	16	15	23	34	28	15	B	1RRI225B00NL
1" x 3/8"	16	19	11	22	40	35	20	B	1RRI232A00NL
1" x 1/2"	16	19	15	25	40	35	24	B	1RRI232B00NL
1" x 3/4"	16	19	16	27	40	35	26	B	1RRI232C00NL
1 1/4" x 1/2"	16	21	15	27	52	44	37	B	1RRI240B00NL
1 1/4" x 3/4"	16	21	16	28	52	44	37	B	1RRI240C00NL
1 1/4" x 1"	16	21	19	31	52	44	40	B	1RRI240D00NL
1 1/2" x 3/4"	16	21	16	29	58	51	47	B	1RRI250C00NL
1 1/2" x 1"	16	21	19	34	58	51	52	B	1RRI250D00NL
1 1/2" x 1 1/4"	16	21	21	34	51	55	79	A	1RRI250E00
2" x 1"	16	26	19	37	70	64	80	B	1RRI263D00NL
2" x 1 1/4"	16	26	21	39	70	64	85	B	1RRI263E00NL
2" x 1 1/2"	16	26	21	37	58	65	105	A	1RRI263F00
2 1/2" x 1 1/2"	16	30	21	43	58	80	145	A	1RRI275F00
2 1/2" x 2"	16	30	26	43	72	80	160	A	1RRI275G00
3" x 2"	16	33	26	47	72	95	215	A	1RRI290G00
3" x 2 1/2"	16	33	30	47	89	95	230	A	1RRI290H00
4" x 3"	16	39	33	53	103	120	200	A	1RRI211I00



MG2

Reducer: BSP threaded male reduced end, BSP threaded female end

R x G	PN	L ₁	L ₂	Z	O	E	g	Code
3/8" x 1/2"	16	11	15	22	30	28	27	1RMG216B00
1/2" x 3/4"	16	15	16	24	36	34	15	1RMG220C00
3/4" x 1"	16	16	19	26	46	42	40	1RMG225D00
1" x 1 1/4"	16	19	21	30	55	51	72	1RMG232E00
1 1/4" x 1 1/2"	16	21	21	33	60	58	83	1RMG240F00
1 1/2" x 2"	16	21	26	34	75	72	125	1RMG250G00
2" x 2 1/2"	16	26	30	38	90	89	202	1RMG263H00
2 1/2" x 3"	16	30	33	44	105	103	240	1RMG275I00
3" x 4"	16	33	39	48	130	130	333	1RMG290L00

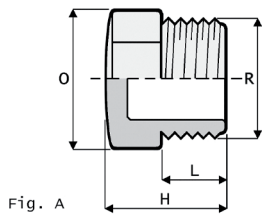

Fig. A

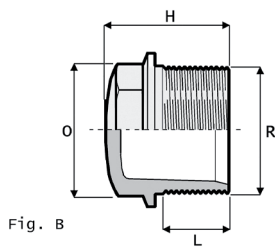
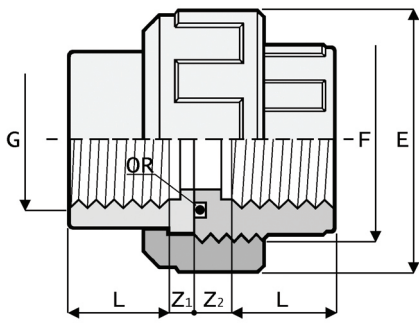

Fig. B

TA2

Plug with BSP male thread

R	PN	L	H	O	g	Fig.	Code
3/8"	16	11	22	22	4	B	1RTA216000NL
1/2"	16	15	26	28	8	B	1RTA220000NL
3/4"	16	16	30	34	11	B	1RTA225000NL
1"	16	19	34	40	21	B	1RTA232000NL
1 1/4"	16	21	38	52	30	B	1RTA240000NL
1 1/2"	16	21	40	58	46	B	1RTA250000NL
2"	16	26	43	65	80	A	1RTA263000
2 1/2"	16	30	51	80	160	A	1RTA275000
3"	16	33	55	95	235	A	1RTA290000
4"	16	39	61	120	360	A	1RTA211000



BO2

Union with BSP threaded female ends, with O-Ring in EPDM (FKM on request)

G	PN	L	Z ₁	Z ₂	F	E	O-R	g	Code
3/8"	16	11	6	14	3/4"	34	3062	32	1RBO216000
1/2"	16	15	4	11	1"	42	4081	44	1RBO220000
3/4"	16	16	6	13	1 1/4"	52	4112	72	1RBO225000
1"	16	19	6	13	1 1/2"	59	4131	100	1RBO232000
1 1/4"	16	21	8	17	2"	72	6162	161	1RBO240000
1 1/2"	16	21	13	24	2 1/4"	79	6187	264	1RBO250000
2"	16	26	15	30	2 3/4"	96	6237	454	1RBO263000
2 1/2"	16	30	18	33	3 1/2"	120	6300	620	1RBO275000L
3"	16	33	26	37	4"	135	6362	810	1RBO290000L
4"	16	39	28	41	5"	163	6450	1350	1RBO211000L

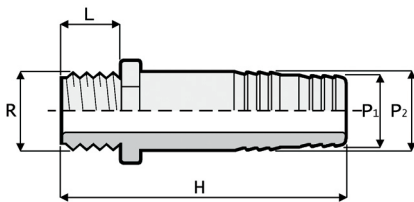

PO2

Hose adaptor with BSP threaded male end

R x P ₁ x P ₂	PN	L	H	g	Code
3/8" x 16 x 18	16	11	58	14	1RPO216000
1/2" x 20 x 22	16	15	66	19	1RPO220000
3/4" x 25 x 27	16	16	81	30	1RPO225000
1" x 30 x 32	16	19	97	45	1RPO232000
1 1/4" x 40 x 42	16	21	104	85	1RPO240000
1 1/2" x 50 x 52	16	21	111	120	1RPO250000
2" x 60 x 64	16	26	123	180	1RPO263000

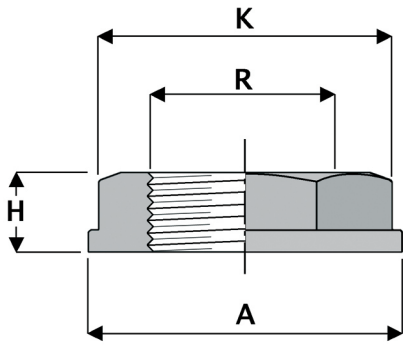

NU2
Union nut with BSP thread for unions

R	PN	A	K	H	g	Code
1/2"	16	38	28	13	11	1RNU220000
3/4"	16	44	33	13	14	1RNU225000
1"	16	58	46	16	31	1RNU232000
1 1/4"	16	62	50	18	32	1RNU240000
1 1/2"	16	76	60	19	52	1RNU250000
2"	16	92	79	20	84	1RNU263000

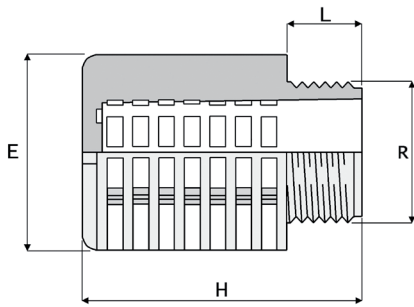

FLT
Male threaded not return filter

R	PN	L	H	E	g	Code
3/4"	16	12	55	37	28	20FLT18M2G025
1"	16	16	69	47	55	20FLT18M2G032
1 1/4"	16	16	83	59	100	20FLT18M2G040
1 1/2"	16	16	91	66	125	20FLT18M2G050
2"	16	15	109	81	220	20FLT18M2G063

TRANSITION SERIES DIN/BSP

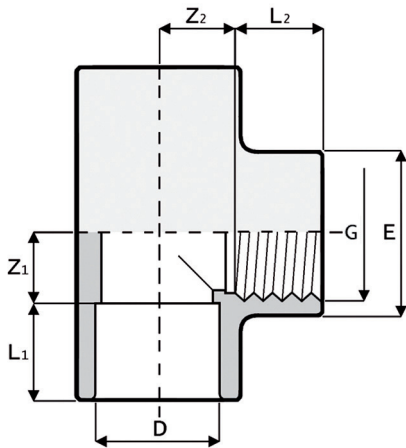

TI3

90° Tee with solvent weld socket and BSP threaded female end

D x G	PN	L ₁	L ₂	Z ₁	Z ₂	E	g	Code
16 x 3/8"	16	14	11	9	12	23	40	1RTI316A00
20 x 1/2"	16	16	15	12	13	28	32	1RTI320B00
25 x 3/4"	16	19	16	15	17	35	52	1RTI325C00
32 x 1"	16	22	19	18	21	43	71	1RTI332D00
40 x 1 1/4"	16	26	21	22	27	50	110	1RTI340E00NL
50 x 1 1/2"	16	31	15	27	28	61	160	1RTI350F00NL
63 x 2"	16	38	26	34	46	76	405	1RTI363G00NL

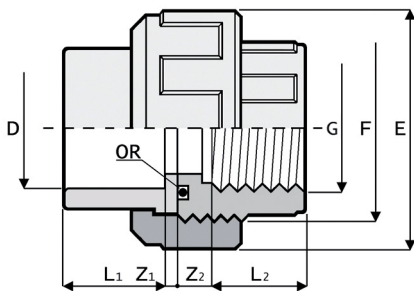

BO3

Union with solvent weld socket and BSP threaded female end, with O-Ring in EPDM (FKM on request)

D x G	PN	L ₁	L ₂	Z ₁	Z ₂	F	E	O-R	g	Code
16 x 3/8"	16	14	11	3	14	3/4"	34	3062	31	1RBO316A00
20 x 1/2"	16	16	15	3	11	1"	42	4081	42	1RBO320B00
25 x 3/4"	16	19	16	3	13	1 1/4"	52	4112	70	1RBO325C00
32 x 1"	16	22	19	3	13	1 1/2"	59	4131	96	1RBO332D00
40 x 1 1/4"	16	26	21	3	17	2"	72	6162	155	1RBO340E00
50 x 1 1/2"	16	31	21	3	24	2 1/4"	79	6187	237	1RBO350F00
63 x 2"	16	38	26	3	30	2 3/4"	96	6237	405	1RBO363G00
75 x 2 1/2"	10	45	30	3	33	3 1/2"	120	6300	620	1RBO375H00L
90 x 3"	10	53	33	5	37	4"	135	6362	810	1RBO390I00L
110 x 4"	10	61	39	5	41	5"	163	6450	1350	1RBO311L00L

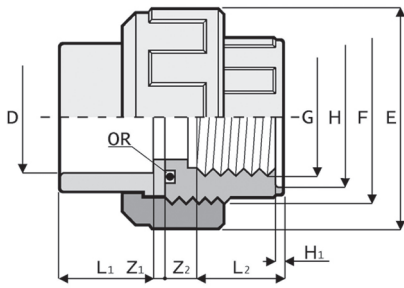

BO3SG

Union with O-ring ISO/female threaded version

D x G	PN	L ₁	L ₂	Z ₁	Z ₂	F	H	H ₁	E	O-R	g	Code
50 x 1 1/2	16	31	21	3	24	2 1/4	57	4	79	6187	237	1RBO350F00AT
63 x 2"	16	38	25	3	30	2 3/4	70	4	96	6237	405	1RBO363G00AT
75 x 2 1/2	16	45	30	3	33	3 1/2	86	4	119	6312	620	1RBO375H00LSG
90 x 3"	16	53	33	5	37	4"	98	4	135	6362	810	1RBO390I00LSG

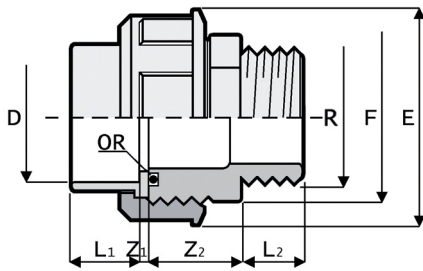

BM3

Union with fixed BSP threaded male end and O-Ring in EPDM (FKM on request)

D x R	PN	L ₁	L ₂	Z ₁	Z ₂	F	E	O-R	g	Code
50 x 1 1/2	16	31	28	3	41	2 1/4	79	6187	270	1RBM350F00
50 x 2"	16	31	28	3	41	2 1/4	79	6187	258	1RBM350G00
63 x 2"	16	38	28	3	43	2 3/4	96	6237	406	1RBM363G00

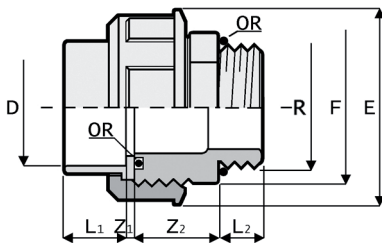

BM3C

Male union with short male thread and external O-ring

D x R	PN	L ₁	L ₂	Z ₁	Z ₂	F	E	O-R	g	Code
50 x 1 1/2	16	31	18	3	41	2 1/4	79	6187	260	1RBM350F00C
63 x 2"	16	38	22	3	43	2 3/4	96	6237	400	1RBM363G00C

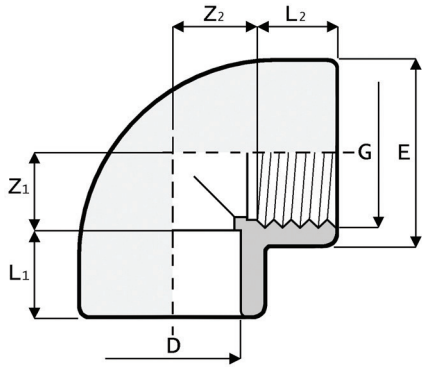

GO3

90° elbow with solvent weld socket and BSP threaded female end

D x G	PN	L ₁	L ₂	Z ₁	Z ₂	E	g	Code
16 x 3/8"	16	14	11	9	12	23	25	1RGO316A00
20 x 1/2"	16	16	15	11	12	28	25	1RGO320B00
25 x 3/4"	16	19	16	14	17	35	40	1RGO325C00
32 x 1"	16	22	19	18	21	43	72	1RGO332D00
40 x 1 1/4"	16	26	21	21	26	51	95	1RGO340E00
50 x 1 1/2"	16	31	21	26	36	61	165	1RGO350F00
63 x 2"	16	38	26	33	46	76	320	1RGO363G00
75 x 2 1/2"	16	44	30	39	53	89	417	1RGO375H00
90 x 3"	16	51	33	47	65	106	690	1RGO390I00
110 x 4"	16	61	39	57	79	129	1035	1RGO311L00

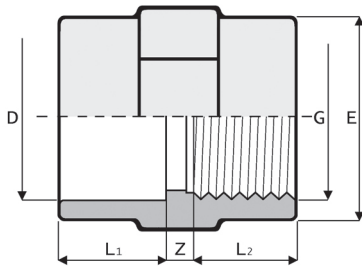

MA3

Double socket with solvent weld socket and BSP threaded female end

D x G	PN	L ₁	L ₂	Z	E	g	Code
16 x 3/8"	16	14	11	6	24	12	1RMA316A00
20 x 1/2"	16	16	15	4	29	20	1RMA320B00
25 x 3/4"	16	19	16	5	35	30	1RMA325C00
32 x 1"	16	22	19	6	43	48	1RMA332D00
40 x 1 1/4"	16	26	21	5	50	56	1RMA340E00
50 x 1 1/2"	16	31	21	8	61	102	1RMA350F00
63 x 2"	16	38	26	8	76	181	1RMA363G00

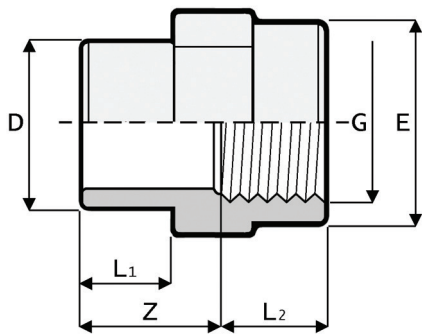

AF3

Double adaptor with solvent weld socket, solvent weld spigot and BSP threaded female end

D x G	PN	L ₁	L ₂	E	Z	g	Code
16 x 3/8"	16	14	15	23	18	9	1RAF316A00
20 x 1/2"	16	16	19	28	21	17	1RAF320B00
20 x 3/4"	16	16	19	34	23	23	1RAF320C00
25 x 1/2"	16	19	17	28	27	19	1RAF325B00
25 x 3/4"	16	19	19	34	27	25	1RAF325C00
25 x 1"	16	19	22	42	26	40	1RAF325D00
32 x 3/4"	16	22	19	34	29	29	1RAF332C00
32 x 1"	16	22	22	42	26	32	1RAF332D00
40 x 1"	16	26	22	42	34	45	1RAF340D00
40 x 1 1/4	16	26	24	51	34	60	1RAF340E00
50 x 1 1/4	16	31	27	51	36	76	1RAF350E00
50 x 1 1/2	16	31	24	61	39	92	1RAF350F00
50 x 2"	16	31	28	72	39	120	1RAF350G00
63 x 1 1/2	16	38	24	61	47	123	1RAF363F00
63 x 2"	16	38	28	72	47	131	1RAF363G00
75 x 2"	16	44	28	72	54	175	1RAF375G00
75 x 2 1/2	16	44	33	89	56	220	1RAF375H00
75 x 3"	16	44	38	103	55	295	1RAF375I00
90 x 2 1/2	16	51	33	89	63	240	1RAF390H00
90 x 3"	16	51	39	103	61	314	1RAF390I00
110 x 3"	16	61	37	103	72	490	1RAF311I00
110 x 4"	16	61	43	129	73	485	1RAF311L00

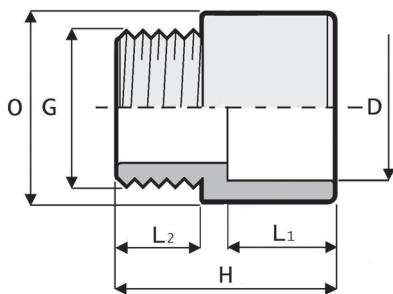

AL3

ISO/female threaded adaptor

D x G	PN	L ₁	L ₂	H	O	g	Code
50 x 1 1/2	16	32	30	67	62	90	1RAL350F00
63 x 2"	16	39	35	80	76	142	1RAL363G00
75 x 2 1/2	16	44	40	108	95	300	1RAL375H00

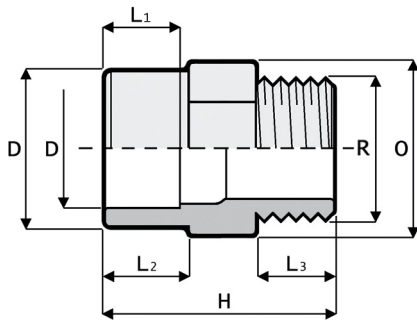

AM3

Double adaptor with solvent weld socket, solvent weld spigot and BSP threaded male end

D x D x R	PN	L ₁	L ₂	L ₃	H	O	g	Code
16 x 20 x 3/8"	16	14	16	11	40	24	10	1RAM316A00
16 x 20 x 1/2"	16	14	16	15	43	24	15	1RAM316B00
20 x 25 x 1/2"	16	16	19	15	46	30	15	1RAM320B00
20 x 25 x 3/4"	16	16	19	16	47	30	20	1RAM320C00
25 x 32 x 1/2"	16	19	22	15	49	36	25	1RAM325B00
25 x 32 x 3/4"	16	19	22	16	50	36	25	1RAM325C00
25 x 32 x 1"	16	19	22	19	53	36	45	1RAM325D00
32 x 40 x 3/4"	16	22	26	16	54	46	40	1RAM332C00
32 x 40 x 1"	16	22	26	19	57	46	40	1RAM332D00
32 x 40 x 1 1/4"	16	22	26	21	60	46	55	1RAM332E00
40 x 50 x 1"	16	26	31	19	64	55	70	1RAM340D00
40 x 50 x 1 1/4"	16	26	31	21	67	55	70	1RAM340E00
40 x 50 x 1 1/2"	16	26	31	21	67	55	70	1RAM340F00
50 x 63 x 1 1/4"	16	31	38	21	74	65	70	1RAM350E00
50 x 63 x 1 1/2"	16	31	38	21	74	65	115	1RAM350F00
50 x 63 x 2"	16	31	38	26	78	65	125	1RAM350G00
63 x 75 x 1 1/2"	16	38	44	21	80	80	198	1RAM363F00
63 x 75 x 2"	16	38	44	26	84	80	160	1RAM363G00
63 x 75 x 2 1/2"	16	38	44	30	91	80	195	1RAM363H00
75 x 90 x 2"	16	44	51	26	93	95	275	1RAM375G00
75 x 90 x 2 1/2"	16	44	51	30	98	95	280	1RAM375H00
75 x 90 x 3"	16	44	51	34	100	95	300	1RAM375I00
90 x 110 x 2 1/2"	16	51	61	30	108	110	370	1RAM390H00
90 x 110 x 3"	16	51	61	34	113	110	390	1RAM390I00
90 x 110 x 4"	16	51	61	39	128	128	420	1RAM390L00
110 x 125 x 3"	16	61	69	34	120	128	450	1RAM311I00
110 x 125 x 4"	16	61	69	39	126	128	500	1RAM311L00

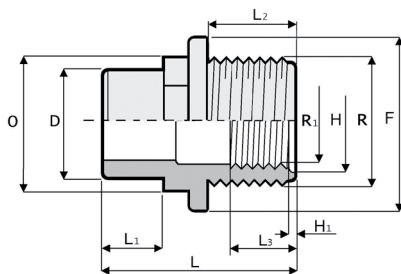

AM3SG

ISO/Threaded male adaptor

D x R x R	PN	L ₁	L ₂	L ₃	L	H	H ₁	F	O	g	Code
50 x 1 1/2 x 2"	16	32	40	34	96	53	2	82	55	145	1RAM350GF0SG

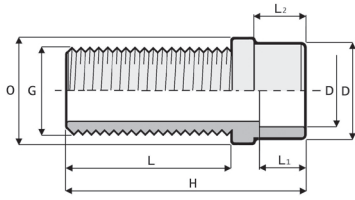

AP3

Wall entry with female thread

$D_1 \times D \times G$	PN	L	L_1	L_2	H	O	g	Code
40 x 50 x 1"1/2	16	106	27	31	148	55	150	1RAP340F00
50 x 63 x 2"	16	100	32	38	148	68	220	1RAP350G00

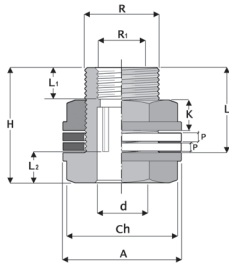

AS3

Tank connector with solvent weld spigot, threaded joint with tightening nut and flat gasket in EPDM

$R \times d \times R_1$	PN	A	Ch	L	L_1	L_2	H	P	K	g	Code
3/4" x 16 x 1/2"	16	44	33	47	15	14	61	3	14	53	1RAS316B00
1" x 20 x 3/4"	16	58	46	49	16	16	65	3	16	108	1RAS320C00
1"1/4 x 25 x 1"	16	62	50	52	19	19	70	3	18	142	1RAS325D00
1"1/2 x 32 x 1"	16	76	60	54	19	22	73	3	19	192	1RAS332D00
2" x 40 x 1"1/2	16	92	79	60	21	26	81	3	21	337	1RAS340F00

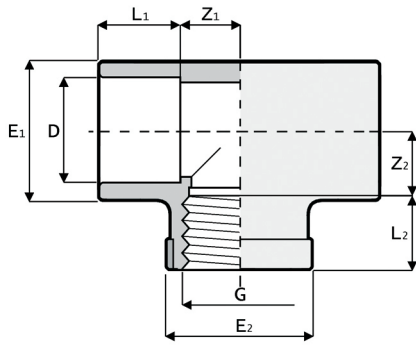

TM3

90° Tee with reinforced end: solvent weld socket and BSP threaded female branch with stainless steel reinforcing ring

D x G	PN	L ₁	L ₂	Z ₁	Z ₂	E ₁	E ₂	g	Code
16 x 3/8"	16	14	11	9	12	42	35	35	1RTM316A00
20 x 1/2"	16	16	15	11	12	51	45	45	1RTM320B00
25 x 3/4"	16	19	16	14	17	61	55	55	1RTM325C00
32 x 1"	16	22	19	17	20	42	45	75	1RTM332D00
40 x 1 1/4"	16	26	21	22	27	50	51	125	1RTM340E00NL
50 x 1 1/2"	16	31	21	27	37	61	62	210	1RTM350F00NL
63 x 2"	16	38	26	34	46	76	77	415	1RTM363G00NL

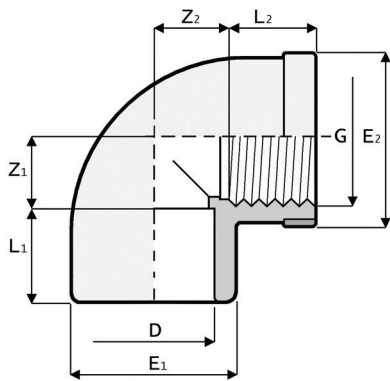

GM3

90° elbow with reinforced solvent weld socket and BSP threaded female end with stainless steel reinforcing ring

D x G	PN	L ₁	L ₂	Z ₁	Z ₂	E ₁	E ₂	g	Code
16 x 3/8"	16	14	11	9	12	23	25	25	1RGM316A00
20 x 1/2"	16	16	15	11	12	28	30	25	1RGM320B00
25 x 3/4"	16	19	16	14	17	35	36	48	1RGM325C00
32 x 1"	16	22	19	18	21	43	44	85	1RGM332D00
40 x 1 1/4"	16	26	21	21	26	51	55	95	1RGM340E00
50 x 1 1/2"	16	31	21	26	36	61	65	165	1RGM350F00
63 x 2"	16	38	26	33	45	75	78	280	1RGM363G00

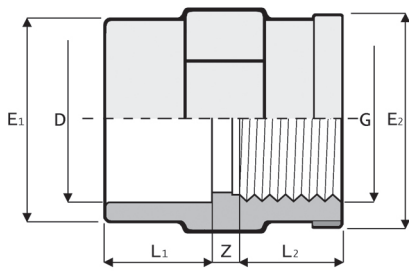

MM3

Double socket with solvent weld socket and BSP threaded female end with stainless steel reinforcing ring

D x G	PN	L ₁	L ₂	E ₁	E ₂	Z	g	Code
16 x 3/8"	16	14	11	24	25	6	14	1RMM316A00
20 x 1/2"	16	16	15	29	30	4	23	1RMM320B00
25 x 3/4"	16	19	16	35	36	5	34	1RMM325C00
32 x 1"	16	22	19	43	44	6	53	1RMM332D00
40 x 1 1/4"	16	26	21	50	51	5	62	1RMM340E00
50 x 1 1/2"	16	31	21	61	62	8	110	1RMM350F00
63 x 2"	16	38	26	76	77	8	190	1RMM363G00

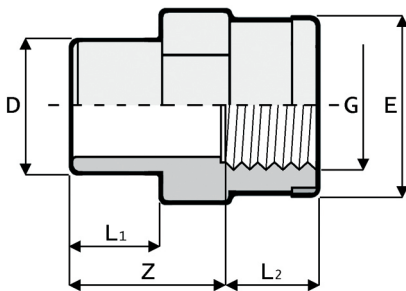

RM3

Double adaptor with solvent weld socket, solvent weld spigot and BSP threaded female end with stainless steel reinforcing ring

D x G	PN	L ₁	L ₂	E	Z	g	Code
20 x 1/2"	16	16	15	30	26	20	1RRM320B00
25 x 1/2"	16	16	19	30	29	20	1RRM325B00
25 x 3/4"	16	19	16	35	29	30	1RRM325C00
32 x 3/4"	16	19	22	35	32	30	1RRM332C00
32 x 1"	16	22	19	45	33	40	1RRM332D00
40 x 1"	16	22	21	45	37	50	1RRM340D00
40 x 1 1/4"	16	26	21	55	37	53	1RRM340E00
50 x 1 1/2"	16	31	21	65	42	100	1RRM350F00
50 x 2"	16	31	26	78	42	125	1RRM350G00
63 x 2"	16	38	26	78	50	140	1RRM363G00

ACCESSORIES AND SPARE PARTS

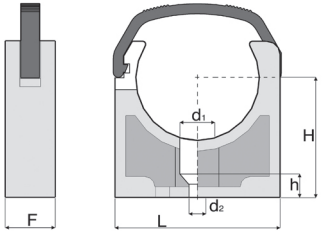
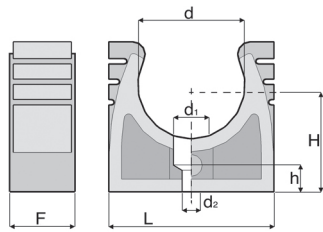

ST1

Pipe clip for ISO-DIN pipes (available also in PE)

D	PN	H	L	d ₂	d ₁	h	f	Fig.	g	Code
16	16	23	28	5	10	7	16	A	5	1RST116000
20	16	25	33	5	10	7	16	A	7	1RST120000
25	16	27	38	5	10	7	16	A	8	1RST125000
32	16	31	48	5	10	7	16	A	13	1RST132000
40	16	41	54	5	10	7	20	B	23	1RST140000
50	16	46	64	7	14	9	23	B	29	1RST150000
63	16	56	80	8	14	9	25	B	39	1RST163000
75	16	63	94	9	17	10	27	B	55	1RST175000
90	16	72	115	9	17	13	30	B	85	1RST190000
110	16	84	139	9	17	14	30	B	100	1RST111000

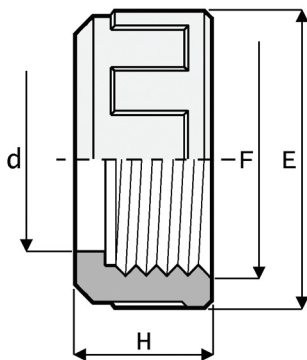

BG1

Union nut with BSP thread for union types for B01, B02 and B03

D	d	H	F	E	g	Code
16	22	23	3/4"	34	10	1RBG116000
20	28	23	1"	42	20	1RBG120000
25	36	25	1 1/4"	52	30	1RBG125000
32	42	27	1 1/2"	59	40	1RBG132000
40	53	30	2"	72	59	1RBG140000
50	59	34	2 1/4"	79	75	1RBG150000
63	74	38	2 3/4"	96	108	1RBG163000
75	93	45	3 1/2"	120	198	1RBG175000L
90	106	52	4"	135	278	1RBG190000L
110	130	59	5"	163	448	1RBG111000L

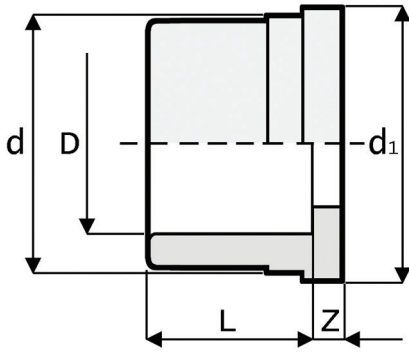

BL1

Union end for solvent welding, metric series for union types B01 and B03

D	L	Z	d	d ₁	g	Code
16	14	3	22	24	5	1RBL16000NL
20	16	3	28	30	8	1RBL120000NL
25	19	3	36	39	15	1RBL125000NL
32	22	3	42	45	24	1RBL132000NL
40	26	3	53	57	37	1RBL140000NL
50	31	3	59	63	42	1RBL150000NL
63	38	3	74	78	77	1RBL163000NL

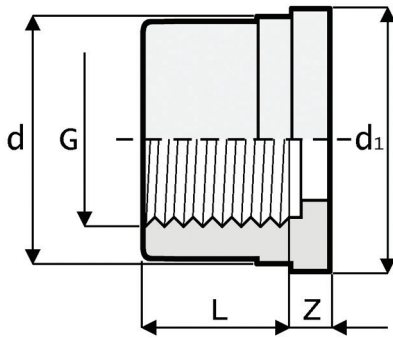

BL2

Union end with BSP female thread for union type for B02

G	L	Z	d	d ₁	g	Code
3/8"	11	6	22	24	11	1RBL216000
1/2"	15	4	28	30	11	1RBL220000
3/4"	16	6	36	39	15	1RBL225000
1"	19	6	42	45	24	1RBL232000
1 1/4"	21	8	53	57	58	1RBL240000
1 1/2"	21	12	59	63	70	1RBL250000
2"	26	15	74	78	105	1RBL263000
2 1/2"	30	18	91	97	165	1RBL275000
3"	33	26	105	110	170	1RBL290000
4"	39	28	129	136	331	1RBL211000

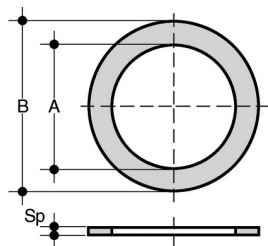

ASGP
Flat gasket for AS3

D	Code
16	GP0195E
20	GP2299E
25	GP0200E
32	GP0201E
40	GP0202E

BS PLAIN SERIES

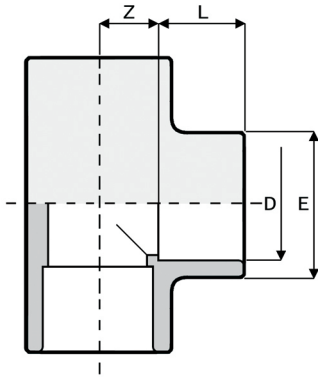

T14

Tee 90° equal, socket for solvent welding BS series

D	PN	L	Z	E	g	Code
1/2"	16	17	11	27	26	1RTI420000NL
3/4"	16	20	14	33	30	1RTI425000NL
1"	16	23	17	41	55	1RTI432000NL
1 1/4"	16	26	22	50	90	1RTI440000NL
1 1/2"	16	31	27	61	257	1RTI450000NL
2"	16	38	34	76	495	1RTI463000NL
3"	16	51	48	108	970	1RTI490000NL
4"	16	63	59	133	1480	1RTI41000
6"	16	86	82	186	3855	1RTI417000

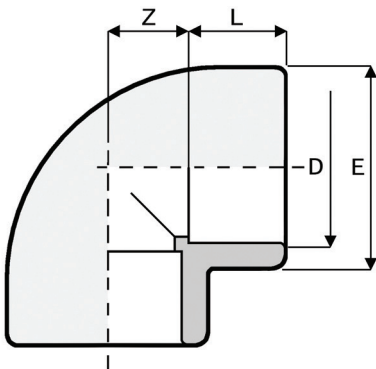

GO4

Elbow 90°, socket for solvent welding BS series

D	PN	L	Z	E	g	Code
1/2"	16	17	11	27	15	1RGO420000NL
3/4"	16	20	14	33	30	1RGO425000NL
1"	16	23	17	41	45	1RGO432000NL
1 1/4"	16	27	22	54	110	1RGO440000NL
1 1/2"	16	31	27	61	160	1RGO450000NL
2"	16	38	34	76	340	1RGO463000NL
3"	16	51	47	106	600	1RGO490000
4"	16	63	58	131	972	1RGO41000NL
6"	16	86	82	186	2920	1RGO417000

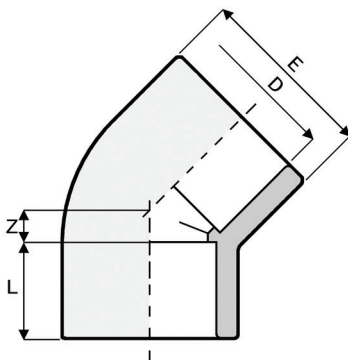

GY4

Elbow 45°, socket for solvent welding BS series

D	PN	L	Z	E	g	Code
1/2"	16	17	5	27	13	1RGY420000NL
3/4"	16	20	6	33	20	1RGY425000NL
1"	16	23	7	41	45	1RGY432000NL
1 1/4"	16	26	11	50	85	1RGY440000NL
1 1/2"	16	31	12	61	155	1RGY450000NL
2"	16	38	14	75	230	1RGY463000
3"	16	51	22	108	565	1RGY490000NL
4"	16	61	26	131	740	1RGY411000NL
6"	16	86	35	186	2265	1RGY417000

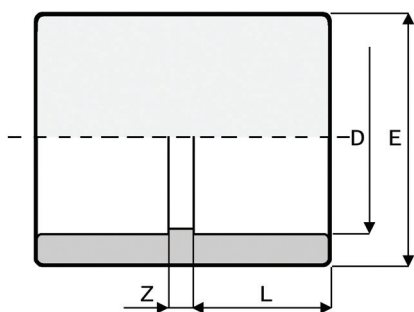

MA4

Double socket for solvent welding BS series

D	PN	L	Z	E	g	Code
1/2"	16	17	2	27	13	1RMA420000NL
3/4"	16	20	2	33	15	1RMA425000NL
1"	16	23	2	41	36	1RMA432000NL
1 1/4"	16	26	3	50	58	1RMA440000NL
1 1/2"	16	31	3	61	118	1RMA450000NL
2"	16	38	3	75	140	1RMA463000
3"	16	51	20	106	355	1RMA490000
4"	16	63	5	131	680	1RMA411000NL
6"	16	86	8	182	1380	1RMA417000

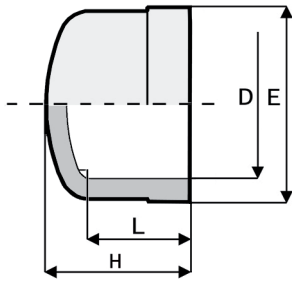

CA4

End cap, socket for solvent welding BS series

D	PN	L	H	E	g	Code
1/2"	16	16	24	28	49	1RCA420000
3/4"	16	20	27	33	15	1RCA425000NL
1"	16	23	31	41	36	1RCA432000NL
1 1/4"	16	26	36	50	58	1RCA440000NL
1 1/2"	16	31	43	61	118	1RCA450000NL
2"	16	38	52	76	206	1RCA463000NL
75	16	44	59	91	190	1RCA175000NL
3"	16	51	69	108	420	1RCA490000NL
4"	16	63	82	131	680	1RCA411000NL
6"	16	86	123	182	1080	1RCA417000

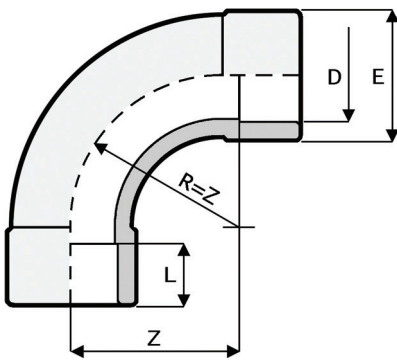

CU4

Bend 90° Long Radius (R=2d), socket for solvent welding BS series

D	PN	L	Z	E	g	Code
1/2"	16	16	40	28	45	1RCU420000
3/4"	16	19	50	36	75	1RCU425000
1"	16	22	64	41	120	1RCU432000
1 1/4"	16	26	80	51	205	1RCU440000
1 1/2"	16	31	100	65	310	1RCU450000
2"	16	38	126	77	510	1RCU463000
3"	16	51	180	113	1765	1RCU490000
4"	16	61	220	137	2805	1RCU411000

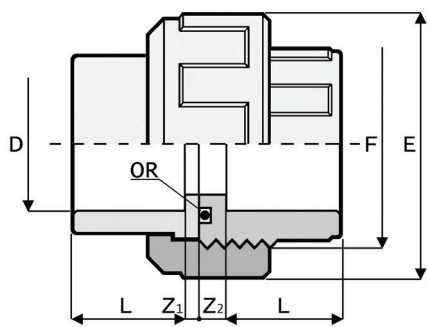

BO4

Socket union, socket for solvent welding, with EPDM gasket BS series

D	PN	L	Z ₁	Z ₂	F	E	O-R	g	Code
1/2"	16	16	3	10	1"	42	4081	42	1RBO420000
3/4"	16	19	3	10	1 1/4"	52	4112	70	1RBO425000
1"	16	22	3	10	1 1/2"	59	4131	97	1RBO432000
1 1/4"	16	26	3	12	2"	72	6162	156	1RBO440000
1 1/2"	16	31	3	14	2 1/4"	79	6187	216	1RBO450000
2"	16	38	3	18	2 3/4"	96	6237	368	1RBO463000
3"	16	51	5	18	4"	135	6362	770	1RBO490000L
4"	16	61	5	18	5"	163	6450	1300	1RBO411000L

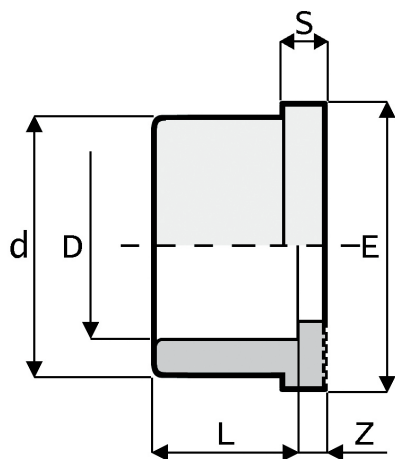

QR4

Serrated stub according to DIN 8063 PN10/16 for flat gasket, socket BS for solvent welding

D	PN	L	Z	d	S	E	g	Code
1"	16	22	3	41	7	50	26	1RQR432000
1 1/2"	16	31	4	61	8	73	63	1RQR450000
2"	16	38	4	76	9	90	112	1RQR463000
3"	16	51	5	108	11	125	273	1RQR490000
4"	16	61	5	131	12	150	439	1RQR411000
6"	16	86	5	188	16	216	1250	1RQR417000NL

TRANSITION SERIES BS/BSP

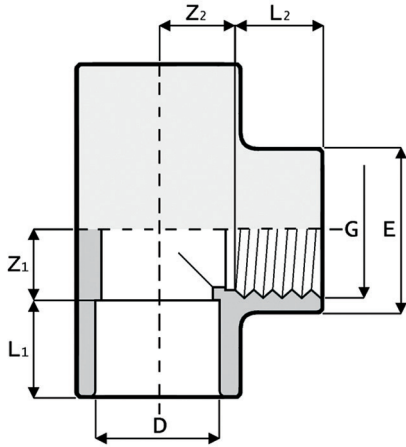

TI6

Tee 90° BS plain/BSP threaded

D x G	PN	L ₁	L ₂	Z ₁	Z ₂	E	g	Code
1/2" x 1/2"	16	16	15	12	13	28	32	1RTI620000
3/4" x 3/4"	16	19	16	15	17	35	52	1RTI625000

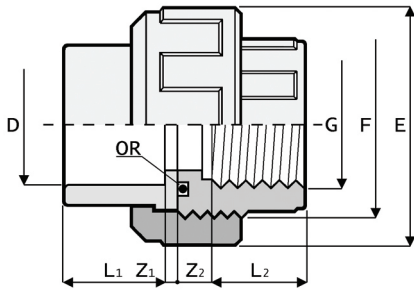

BO6

Socket union, socket BS solvent welding/BSP Threaded, with EPDM oring

D x G	PN	L ₁	L ₂	Z ₁	Z ₂	F	E	O-R	g	Code
1"x1"	16	22	19	3	13	1 1/2"	59	4131	96	1RBO632000
1 1/2"x1 1/2"	16	31	21	3	24	2 1/4"	79	6187	237	1RBO650000
2"x2"	16	38	26	3	30	2 3/4"	96	6237	405	1RBO663000
75 x 2 1/2"	16	45	30	3	33	3 1/2"	120	6300	620	1RBO375H00L
3"x3"	16	53	33	5	37	4"	135	6362	810	1RBO690000L

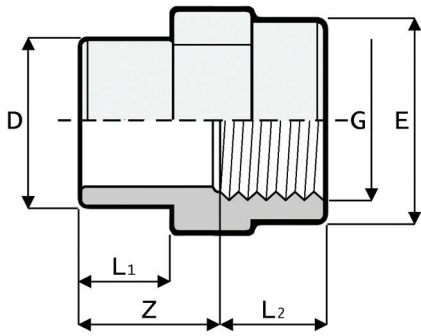

AF6

Female adaptor BS male plain/BSP threaded

D x G	PN	L ₁	L ₂	E	Z	g	Code
1/2" x 1/2"	16	16	19	28	21	17	1RAF620B00
3/4" x 3/4"	16	19	19	34	27	25	1RAF625C00
1" x 1"	16	22	22	42	26	32	1RAF632D00
1 1/4" x 1 1/4"	16	26	24	51	34	60	1RAF640E00
1 1/2" x 1 1/2"	16	31	24	61	39	92	1RAF650F00
2" x 2"	16	38	28	72	47	131	1RAF663G00

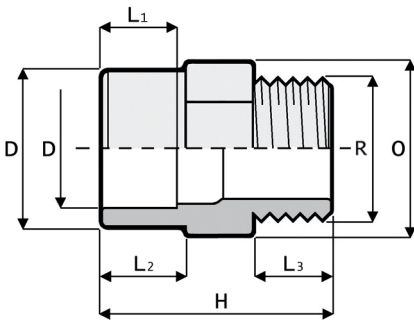

AM6

Female/male adaptor with solvent weld socket d and BSP threaded male end

D x R	PN	L ₁	L ₂	L ₃	H	O	g	Code
1 1/4" x 1 1/4"	16	27	22	20	57	55	65	1RAM640E00NL
2" x 2"	16	36	33	26	73	80	160	1RAM663G00NL
2 1/2" x 2 1/2"	16	44	51	30	99	95	285	1RAM375H00
3" x 3"	16	51	61	33	113	115	490	1RAM690I00

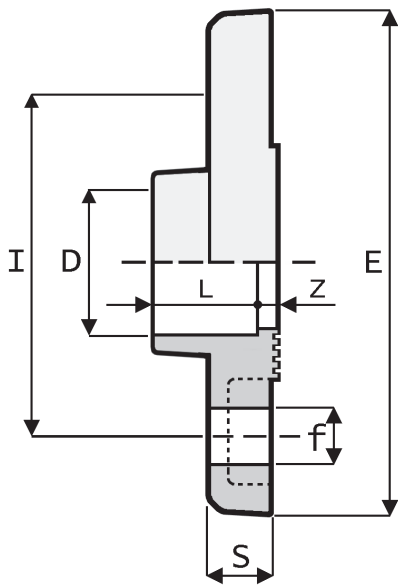

FF5

Fixed flange hole according to ISO DIN 8063/BS plain socket

D	PN	DN	L	Z	E	I	f	S	n°drill	g	Bolts	Code
2"	16	50	38	5	165	125	18	18	4	395	M16x80	1RFF563000
3"	16	80	51	7	200	160	18	20	8	780	M16x90	1RFF590000
4"	16	100	61	8	220	180	18	22	8	1070	M16x100	1RFF511000

ACCESSORIES AND SPARE PARTS

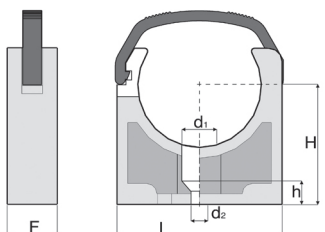
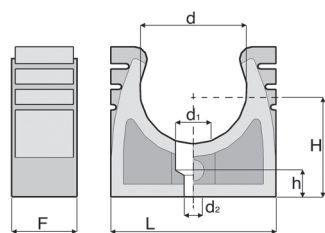

ST4

Pipe clip for BS pipes (available also in PE)

D	PN	H	L	d ₂	d ₁	h	f	Fig.	g	Code
1/2"	16	25	33	5	10	7	16	A	7	1RST416000
3/4"	16	27	38	5	10	7	16	A	8	1RST420000
1"	16	31	48	5	10	7	16	A	13	1RST425000
1 1/4"	16	41	54	5	10	7	20	B	23	1RST432000
1 1/2"	16	46	64	7	14	9	23	B	29	1RST440000
2	16	56	80	7	14	9	25	B	39	1RST450000
2 1/2"	16	63	94	9	17	10	27	B	55	1RST463000
3"	16	72	115	9	17	13	30	B	85	1RST475000
4"	16	84	139	9	17	14	30	B	100	1RST490000
								B		1RST411000

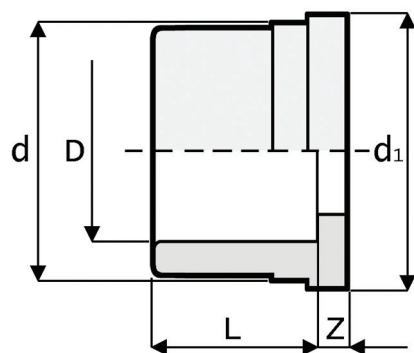

BL4

Union end for solvent welding BS series

D	L	Z	d	d ₁	g	Code
1/2"	16	3	28	30	8	1RBL420000NL
3/4"	19	3	36	39	13	1RBL425000NL
1"	22	3	42	45	19	1RBL432000NL
1 1/4"	26	3	53	57	32	1RBL440000NL
1 1/2"	31	3	59	63	46	1RBL450000NL
2"	38	3	74	78	75	1RBL463000
3"	51	5	105	110	190	1RBL490000
4"	61	5	129	136	335	1RBL411000

INSTALLATION

POSITIONING PIPE CLIPS

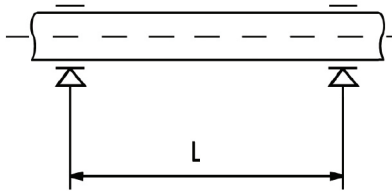

The installation of thermoplastic pipe systems requires the use of support clips to prevent flexing and the resulting mechanical stresses.

The distance between the clips depends on the pipe material, SDR, surface temperature and the density of the conveyed fluid.

Before installing the clips, check the distances reported in the table below, as provided for by guidelines DVS 2210-1 for water pipes.

Supporting PVC-U pipes conveying liquids of density 1 g/cm³ (water and other fluids of equal intensity).

For pipes of SDR 13.6 / S 6.3 / PN 16:

d mm	< 20° C	30° C	40° C	50° C	60° C
16	950	900	850	750	600
20	1100	1050	1000	900	700

For pipes of SDR 21 / S 10 / PN 10:

d mm	< 20° C	30° C	40° C	50° C	60° C
25	1200	1150	1050	950	750
32	1350	1300	1250	1100	900
40	1450	1400	1350	1250	1000
50	1600	1550	1500	1400	1150
63	1800	1750	1700	1550	1300
75	2000	1900	1850	1700	1450
90	2200	2100	2000	1850	1550
110	2400	2300	2250	2050	1750
125	2550	2450	2400	2200	1850
140	2700	2600	2500	2300	1950
160	2900	2800	2700	2500	2100
180	3100	2950	2850	2650	2200

For different SDR values, multiply the data in the table by the following factors:

1.08 for SDR 13.6 / S6.3 / PN16 size range d25 - d400

1.15 for SDR 11 / S5 / PN20 entire size range

Supporting PVC-U pipes conveying liquids of density other than 1 g/cm³

If the liquid being conveyed has a density other than 1 g/cm³, the distance L in the table must be multiplied by the factors in the table below.

Fluid density in g/cm ³	Support factor
1,25	0,96
1,50	0,92
< 0,01	1.42 for SDR 21 / S10 / PN10 1.30 for SDR 13.6 / S6.3 / PN16 1.20 for SDR 11 / S5 / PN20