



Valves handbook

The complete range of FIP valves:
versions, ranges and materials



Handbook Valves

Valves Handbook is a tool that summarizes all FIP valve range.

All types and versions available in a glance as well as their specific accessories and main technical details such Nominal Working Pressure and Kv factors.

This handbook is intended as practical quick reference. It does not substitute FIP catalogues which are the official reference for the products data.

Index

Legenda		4
Graphs Pressure / Temperature		5
VKD DN 10÷50	DUAL BLOCK® 2-Way Ball Valve	6
VKD DN 65÷100	DUAL BLOCK® 2-Way Ball Valve	7
VKR DN 10÷50	DUAL BLOCK® Regulating Ball Valve	8
TKD DN 10÷50	DUAL BLOCK® 3-Way Ball Valve	9
VXE DN 10÷50	Easyfit 2-Way Ball Valve - Multipurpose	10
VXE DN 65÷100	Easyfit 2-Way Ball Valve - Multipurpose	11
VEE DN 10÷50	Easyfit 2-Way Ball Valve - Water	12
VEE DN 65÷100	Easyfit 2-Way Ball Valve - Water	13
SXE DN 10÷50	Easyfit True Union Ball Check Valve	14
SXE DN 65÷100	Easyfit True Union Ball Check Valve	15
SSE DN 10÷50	Easyfit True Union Spring Check Valve	16
SSE DN 65÷100	Easyfit True Union Spring Check Valve	17
SR DN 10÷50	Ball Check Valve	18
FE DN 40÷200	Butterfly Valve - Water	19
FK DN 40÷400	Butterfly Valve - Multipurpose	20
DK DN 15÷65	DIALOCK® 2-way Diaphragm Valve	21
VM DN 80÷100	Diaphragm Valve	22
CM DN 12÷15	Compact Diaphragm Valve	23
VM/RM DN 8÷15	Mini-Valve and Diaphragm Cock Valve	24
RV DN 10÷100	Sediment Strainer	25
VV DN 10÷50	Angle Seat Valve	26
VR DN 10÷100	Angle Seat Check Valve	27
VA DN 15÷50	Air Release Valve	28
VZ DN 10÷50	Foot Valve	29
CR DN 40÷300	Wafer Check Valve	30
FR DN 40÷300	Wafer Check Valve	31
SV DN 15÷25	Angle Seat Pressure Relief Valve	32

VKD/CE DN 10÷100	Electrically Actuated DUAL BLOCK® 2-Way Ball Valve	33
VKD/CP DN 10÷100	Pneumatically Actuated DUAL BLOCK® 2-Way Ball Valve	34
VKR/CE DN 10÷50	Electrically Actuated DUAL BLOCK® Regulating Ball Valve	35
TKD/CE DN 10÷50	Electrically Actuated DUAL BLOCK® 3-Way Ball Valve	36
TKD/CP DN 10÷50	Pneumatically Actuated DUAL BLOCK® 3-Way Ball Valve	37
FE/CE DN 40÷200	Electrically Actuated Butterfly Valve - Water	38
FE/CP DN 40÷200	Pneumatically Actuated Butterfly Valve - Water	39
FK/CE DN 40÷400	Electrically Actuated Butterfly Valve - Multipurpose	40
FK/CP DN 40÷400	Pneumatically Actuated Butterfly Valve - Multipurpose	41
DK/CP DN 15÷65	Pneumatically Actuated 2-way Diaphragm Valve - Piston Type Actuator	42
VM/CP DN 80÷100	Pneumatically Actuated 2-way Diaphragm Valve - Diaphragm Type Actuator	43
DKD/CP DN 15÷65	Direct Action Pneumatically Actuated 2-way Diaphragm Valve	44
CK/CP DN 12÷15	Compact Pneumatically Actuated Diaphragm Valve	45
S12/S22 DN 12÷15	2-Way Solenoid Valves	46
Reference Standards (Dimensions)		47

Legenda

d	Nominal outside diameter of the pipe in mm
DN	Nominal internal diameter in mm
PN	Nominal pressure (max working pressure at 20°C - water)
PVC-U	Unplasticized polyvinylchloride
PP-H	Homopolymer polypropylene
PVC-C	Chlorinated polyvinyl chloride
PVDF	Polyvinylidene fluoride
PE	Polyethylene
EPDM	Ethylene-Propylene-Diene-Monomer
FKM	Fluoroelastomer
PTFE	Polytetrafluoroethylene
NBR	Nitrile butadiene rubber
Kv100 [l/min]	Number of litres per minute of water, at a temperature of 20°C, that will flow through a valve with 1bar differential pressure, at a stated opening rate. The Kv100 values shown in the tables are calculated with the valve fully open.

Pressure /Temperature rating for water and harmless fluids to which the material is resistant.
 In the other cases a reduction of the rated PN is required.

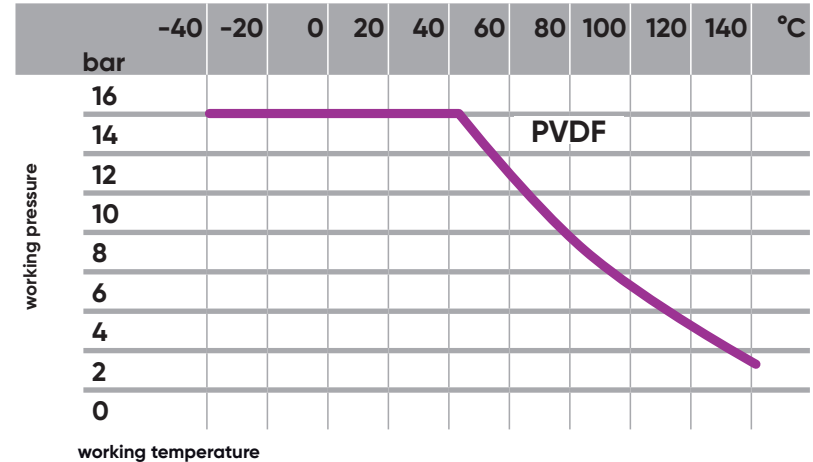
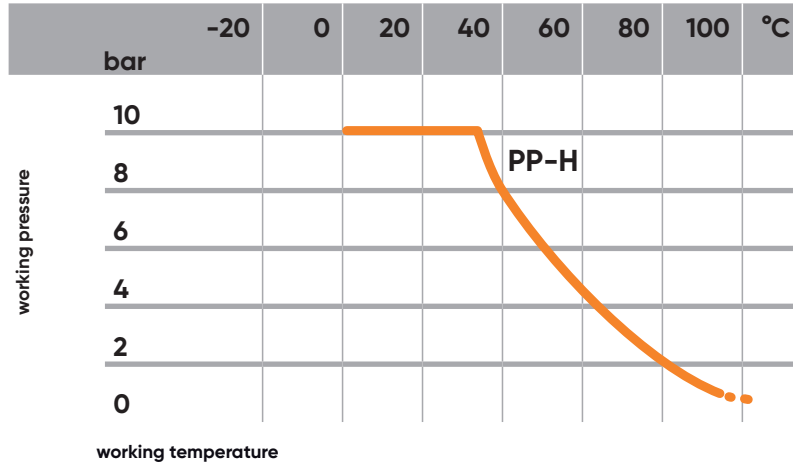
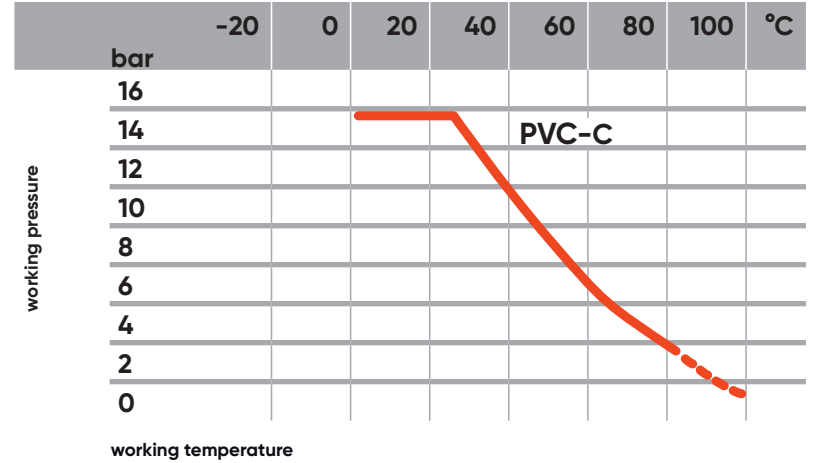
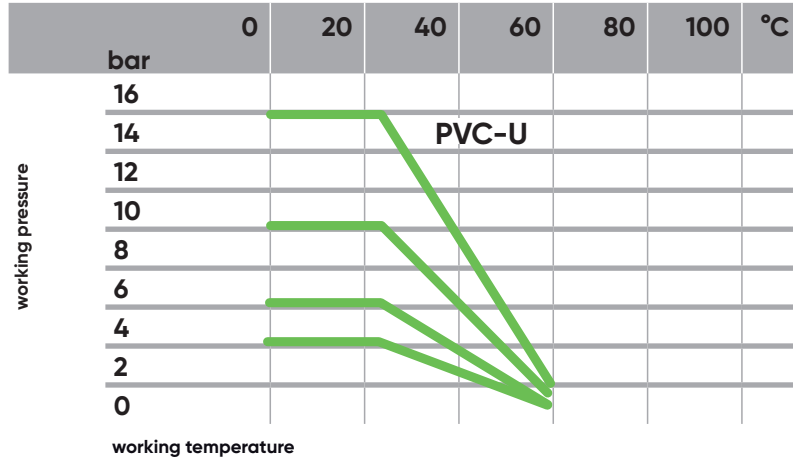

VKD DUAL BLOCK®

DN 10÷50



2-Way Ball Valve

Body materials

PVC-U
PVC-C
PP-H
PVDF

Ball seats material

PTFE

Seals materials

EPDM
FKM

Accessories

Dual Block® System (supplied as standard)
Handle Block (SHKD)
Actuation module (Power Quick)
Mounting Plate (PMKD)
Stem Extension (PSKD)
Limit Switch Box (LSQT) + mounting Kit (LSQKIT)
Easytorque Kit (KET01)

d [mm]		16	20	25	32	40	50	63	
DN [mm]		10	15	20	25	32	40	50	
SIZE [inch]		3/8"	1/2"	3/4"	1"	1" 1/4"	1" 1/2"	2"	Type
ISO-DIN metric series plain female ends	PVC-U	●	●	●	●	●	●	●	VKDIV
	PVC-C	●	●	●	●	●	●	●	VKDIC
	PP-H	●	●	●	●	●	●	●	VKDIM
	PVDF	●	●	●	●	●	●	●	VKDIF
ISO-DIN metric series plain male ends	PVC-U	●	●	●	●	●	●	●	VKDDV
	PVC-C	n.a.	●	●	●	●	●	●	VKDDC
	PP-H	n.a.	●	●	●	●	●	●	VKDDM
	PVDF	n.a.	●	●	●	●	●	●	VKDDF
BSP series threaded female ends	PVC-U	●	●	●	●	●	●	●	VKDFV
	PP-H	●	●	●	●	●	●	●	VKDFM
	PVC-C	o.r.	o.r.	o.r.	o.r.	o.r.	o.r.	o.r.	VKDFC
BS socket welding	PVC-U	●	●	●	●	●	●	●	VKDLV
ASTM series plain female ends	PVC-U	●	●	●	●	●	●	●	VKDAV
	PVC-C	●	●	●	●	●	●	●	VKDAC
NPT series threaded female ends	PVC-U	●	●	●	●	●	●	●	VKDNV
	PVC-C	●	●	●	●	●	●	●	VKDNC
JIS series plain female ends	PVC-U	n.a.	●	●	●	●	●	●	VKDJV
FLANGED ISO-DIN	PVC-U	n.a.	●	●	●	●	●	●	VKDOV
	PVC-C	n.a.	●	●	●	●	●	●	VKDOC
	PP-H	n.a.	●	●	●	●	●	●	VKDOM
	PVDF	n.a.	●	●	●	●	●	●	VKDOF
FLANGED ANSI	PVC-U	n.a.	●	●	●	●	●	●	VKDOAV
	PVC-C	n.a.	●	●	●	●	●	●	VKDOAC
	PP-H	n.a.	●	●	●	●	●	●	VKDOAM
	PVDF	n.a.	●	●	●	●	●	●	VKDOAF
FLANGED JIS K10	PVC-U	n.a.	o.r.	o.r.	o.r.	o.r.	o.r.	o.r.	VKDOJV
	PVC-C	n.a.	o.r.	o.r.	o.r.	o.r.	o.r.	o.r.	VKDOJC
	PP-H	n.a.	o.r.	o.r.	o.r.	o.r.	o.r.	o.r.	VKDOJM
	PVDF	n.a.	o.r.	o.r.	o.r.	o.r.	o.r.	o.r.	VKDOJF
BW Long spigot male ends for butt welding with PE100 SDR 11	PVC-U	●	●	●	●	●	●	●	VKDBEV
	PP-H	●	●	●	●	●	●	●	VKDBEM
BW Long spigot male ends for butt welding	PP-H	●	●	●	●	●	●	●	VKDBM
	PVDF	●	●	●	●	●	●	●	VKDBF
PN [bar] 16 bar = 232 psi 10 bar = 150 psi	PVC-U	16	16	16	16	16	16	16	
	PVC-C	16	16	16	16	16	16	16	
	PP-H	10	10	10	10	10	10	10	
	PVDF	16	16	16	16	16	16	16	
Kv100 [l/min]		80	200	385	770	1100	1750	3400	

Notes: n.a.= not available, o.r.= on request (not in standard production)

VKD DUAL BLOCK®

DN 65÷100



2-Way Ball Valve

Body materials

PVC-U
PVC-C
PP-H
PVDF

Ball seats material

PTFE

Seals materials

EPDM
FKM

Accessories

Dual Block® System (supplied as standard)
Handle Block (SHKD)
Actuation module
Mounting Plate (PMKD)
Stem Extension (PSKD)
Limit Switch Box (LSQT) + mounting Kit (LSQKIT)
Customisation set (LSE)

d [mm]		75	90	110	
DN [mm]		65	80	100	
SIZE [inch]		2" 1/2	3"	4"	Type
ISO-DIN metric series plain female ends	PVC-U	•	•	•	VKDIV
	PVC-C	•	•	•	VKDIC
	PP-H	•	•	•	VKDIM
	PVDF	•	•	•	VKDIF
ISO-DIN metric series plain male ends	PVC-U	•	•	•	VKDDV
	PVC-C	•	•	•	VKDDC
	PP-H	•	•	•	VKDDM
	P VDF	•	•	•	VKDDF
BSP series threaded female ends	PVC-U	•	•	•	VKDFV
	PVC-C	n.a.	n.a.	n.a.	VKDFC
	PP-H	n.a.	n.a.	n.a.	VKDFM
BS socket welding	PVC-U	•	•	•	VKDLV
ASTM series plain female ends	PVC-U	•	•	•	VKDAV
	PVC-C	•	•	•	VKDAC
NPT series threaded female ends	PVC-U	•	•	•	VKDNV
	PVC-C	•	•	•	VKDNC
JIS series plain female ends	PVC-U	•	•	•	VKDJV
FLANGED ISO-DIN	PVC-U	•	•	•	VKDOV
	PVC-C	•	•	•	VKDOC
	PP-H	•	•	•	VKDOM
	PVDF	•	•	•	VKDOF
FLANGED ANSI	PVC-U	•	•	•	VKDOAV
	PVC-C	•	•	•	VKDOAC
	PP-H	•	•	•	VKDOAM
	PVDF	•	•	•	VKDOAF
FLANGED JIS K10	PVC-U	o.r.	o.r.	o.r.	VKDOJV
	PVC-C	o.r.	o.r.	o.r.	VKDOJC
	PP-H	o.r.	o.r.	o.r.	VKDOJM
	PVDF	o.r.	o.r.	o.r.	VKDOJF
BW Long spigot male ends for butt welding with PE100 SDR 11	PVC-U	•	•	•	VKDBEV
	PP-H	•	•	•	VKDBEM
BW Long spigot male ends for butt welding	PP-H	•	•	•	VKDBM
	PVDF	•	•	•	VKDBF
PN [bar] 16 bar = 232 psi 10 bar = 150 psi	PVC-U	16	16	16	
	PVC-C	16	16	16	
	PP-H	10	10	10	
	PVDF	16	16	16	
Kv100 [l/min]		5250	7100	9500	

Notes: n.a.= not available, o.r.= on request (not in standard production)

VKR DUAL BLOCK®

DN 10÷50



Regulating Ball Valve

Body materials

PVC-U
PP-H
PVDF

Ball seats material

PTFE

Seals materials

EPDM
FKM

Accessories

Dual Block® System (supplied as standard)
Mounting Plate (PMKD)
Easytorque Kit (KET01)
Actuation module (Power Quick)
Stem Extension (PSKD)

d [mm]		16	20	25	32	40	50	63	
DN [mm]		10	15	20	25	32	40	50	
SIZE [inch]		3/8"	1/2"	3/4"	1"	1" 1/4"	1" 1/2"	2"	Type
ISO-DIN metric series plain female ends	PVC-U	●	●	●	●	●	●	●	VKRIV
	PP-H	●	●	●	●	●	●	●	VKRIM
	PVDF	●	●	●	●	●	●	●	VKRIF
ISO-DIN metric series plain male ends	PP-H	●	●	●	●	●	●	●	VKRDM
BSP series threaded female ends	PVC-U	●	●	●	●	●	●	●	VKRJV
	PP-H	●	●	●	●	●	●	●	VKRJM
BS socket welding	PVC-U	●	●	●	●	●	●	●	VKRLV
ASTM series plain female ends	PVC-U	●	●	●	●	●	●	●	VKRAV
JIS series threaded female ends	PVC-U	n.a.	●	●	●	●	●	●	VKRGV
	PP-H	n.a.	●	●	●	●	●	●	VKROM
FLANGED ISO-DIN	PVC-U	n.a.	o.r.	o.r.	o.r.	o.r.	o.r.	o.r.	VKROJV
	PP-H	n.a.	o.r.	o.r.	o.r.	o.r.	o.r.	o.r.	VKROJM
	PVDF	n.a.	o.r.	o.r.	o.r.	o.r.	o.r.	o.r.	VKROJF
BW Long spigot male ends for butt welding with PE100 SDR 11	PVC-U	●	●	●	●	●	●	●	VKRBEV
	PP-H	●	●	●	●	●	●	●	VKRBEH
BW Long spigot male ends for butt welding	PP-H	●	●	●	●	●	●	●	VKRBM
	PVDF	●	●	●	●	●	●	●	VKRBF
PN [bar] 16 bar = 232 psi 10 bar = 150 psi	PVC-U	16	16	16	16	16	16	16	
	PP-H	10	10	10	10	10	10	10	
	PVDF	16	16	16	16	16	16	16	
Kv100 [l/min]		83	88	135	256	478	592	1068	

Notes: n.a.= not available, o.r.= on request (not in standard production)

TKD DUAL BLOCK®

DN 10÷50



3-Way Ball Valve

Body materials

PVC-U
PVC-C
PP-H

Ball seats material

PTFE

Seals materials

EPDM
FKM

Functions

T - bore
L - bore

Accessories

Dual Block® System (supplied as standard)
Handle Block (SHKD)
Actuation module (Power Quick)
Mounting Plate (PMKD)
Stem Extension (PSKD)
Limit Switch Box (LSQT) + mounting Kit (LSQKIT)
End connections (Butt Weld.) in PE (CVDE)
End connections (Butt Weld.) in PP-H (CVDM)
Handle stop 90° or 180° (LTKD090 or LTKD180)

d [mm]		16	20	25	32	40	50	63	
DN [mm]		10	15	20	25	32	40	50	
SIZE [inch]		3/8"	1/2"	3/4"	1"	1" 1/4	1" 1/2	2"	Type
ISO-DIN metric series plain female ends	PVC-U	•	•	•	•	•	•	•	TKDIV
	PVC-C	•	•	•	•	•	•	•	TKDIC
	PP-H	•	•	•	•	•	•	•	TKDIM
ISO-DIN metric series plain male ends	PVC-U	•	•	•	•	•	•	•	TKDDV
	PVC-C	n.a.	•	•	•	•	•	•	TKDDC
	PP-H	n.a.	•	•	•	•	•	•	TKDDM
BSP series threaded female ends	PVC-U	•	•	•	•	•	•	•	TKDFV
	PVC-C	•	•	•	•	•	•	•	TKDFC
	PP-H	•	•	•	•	•	•	•	TKDFM
BS socket welding	PVC-U	•	•	•	•	•	•	•	TKDLV
ASTM series plain female ends	PVC-U	•	•	•	•	•	•	•	TKDAV
	PVC-C	•	•	•	•	•	•	•	TKDAC
FLANGED ISO-DIN	PVC-U	n.a.	o.r.	o.r.	o.r.	o.r.	o.r.	o.r.	TKDOV
	PVC-C	n.a.	o.r.	o.r.	o.r.	o.r.	o.r.	o.r.	TKDOC
	PP-H	n.a.	o.r.	o.r.	o.r.	o.r.	o.r.	o.r.	TKDOM
FLANGED ANSI	PVC-U	n.a.	o.r.	o.r.	o.r.	o.r.	o.r.	o.r.	TKDOAV
	PVC-C	n.a.	o.r.	o.r.	o.r.	o.r.	o.r.	o.r.	TKDOAC
	PP-H	n.a.	o.r.	o.r.	o.r.	o.r.	o.r.	o.r.	TKDOAM
FLANGED JIS K10	PVC-U	n.a.	o.r.	o.r.	o.r.	o.r.	o.r.	o.r.	TKDOJV
	PVC-C	n.a.	o.r.	o.r.	o.r.	o.r.	o.r.	o.r.	TKDOJC
	PP-H	n.a.	o.r.	o.r.	o.r.	o.r.	o.r.	o.r.	TKDOJM
PN [bar] 16 bar = 232 psi 10 bar = 150 psi	PVC-U	16	16	16	16	16	16	16	
	PVC-C	16	16	16	16	16	16	16	
	PP-H	10	10	10	10	10	10	10	

Notes: n.a.= not available, o.r.= on request (not in standard production)

VXE Easyfit

DN 10÷50



d [mm]		16	20	25	32	40	50	63	
DN [mm]		10	15	20	25	32	40	50	
SIZE [inch]		3/8"	1/2"	3/4"	1"	1" 1/4	1" 1/2	2"	Type
ISO-DIN metric series plain female ends	PVC-U	•	•	•	•	•	•	•	VXEIV
	PVC-C	•	•	•	•	•	•	•	VXEIC
BSP series threaded female ends	PVC-U	•	•	•	•	•	•	•	VXEIV
	PVC-C	•	•	•	•	•	•	•	VXEFC
BS socket welding	PVC-U	n.a.	•	•	•	•	•	•	VXELV
ASTM series plain female ends	PVC-U	n.a.	•	•	•	•	•	•	VXEAV
	PVC-C	n.a.	•	•	•	•	•	•	VXEAC
BW Long spigot male ends for butt welding with PE100 SDR 11	PVC-U	n.a.	•	•	•	•	•	•	VXEBEV
PN [bar] 16 bar = 232 psi	PVC-U	16	16	16	16	16	16	16	
	PVC-C	16	16	16	16	16	16	16	
Kv100 [l/min]		80	200	385	770	1100	1750	3400	

Notes: n.a.= not available

2-Way Ball Valve

Body materials

PVC-U
PVC-C

Ball seats material

PTFE

Seals materials

EPDM
FKM

Accessories

Transparent protection plug with tag holder (LCE)
Easytorque Kit (KET01)
End connections (Butt Weld.) in PE (CVDE)

Multifunctional handle and Easytorque Kit



Easytorque kit is the innovative tool designed by FIP for optimal tightening and adjustment of all threaded components of the Easyfit valves (carriers and nuts) applying a defined and repeatable torque.

The use of the Easytorque wrench is recommended to minimize mechanical stresses on thermoplastic threads, preventing fluid leakage, optimizing ball valve operation and minimizing the wear out of the elastomeric seals. The use of the Easyfit torque wrench also avoids non specific tools causing union nut accidental damaging..



Nuts tightening



Ball Seat Carrier adjustment

Easyfit Labelling System

Easyfit Labelling System helps you to customize valves with company brands, serial or identifying numbers or service information such as the function of the valve inside the plant, the conveyed fluid, but also specific information for after selling customer service, such as the customer's name, or date and place of the installation.



More details on www.aliaxis.it/en/tools-and-services/easylabelling-software

VXE Easyfit

DN 65÷100



2-Way Ball Valve

Body materials

PVC-U
PVC-C

Ball seats material

PTFE

Seals materials

EPDM
FKM

Accessories

Easyfit Actuation module (Power Quick Easyfit)
Stem extension (PSE)
Transparent protection plug with tag holder (LCE)
Customisation set (LSE)
End connections (Butt Weld.) in PE (CVDE)

d [mm]		75	90	110	
DN [mm]		65	80	100	
SIZE [inch]		2" 1/2	3"	4"	Type
ISO-DIN metric series	PVC-U	•	•	•	VXEIV
plain female ends	PVC-C	•	•	•	VXEIC
BSP series	PVC-U	•	•	•	VXEIV
threaded female ends	PVC-C	•	•	•	VXEFC
BS socket welding	PVC-U	•	•	•	VXELV
ASTM series	PVC-U	•	•	•	VXEAV
plain female ends	PVC-C	•	•	•	VXEAC
BW Long spigot male ends for butt welding with PE100 SDR 11	PVC-U	•	•	•	VXEBEV
PN [bar]	PVC-U	16	16	16	
16 bar = 232 psi	PVC-C	16	16	16	
Kv100 [l/min]		5000	7000	9400	

Easyfit Quick-release Multifunctional Handle



Thanks to the innovative Easyfit System, the handle can be easily released from the hub to carry out the union nuts rotation during valve installation and the ball seat carrier adjustment. The handle can be turned into a wrench key for tightening or loosening the union nuts simply removing, flipping and engaging the insert housed inside it in the appropriate seat. The tool so composed is extremely rugged and light at the same time offering an excellent ergonomic grip. The insert design engages perfectly on the external profile of the union nuts with a secure grip allowing to exercise a high torque without damaging the nuts in any way. The handle can also be used as a tool for disassembly, assembly or adjustment of the support of the ball seat carrier. For this function, once removed the handle from the hub enter the two upper protrusions into the appropriate slots of the seat carrier to screw or unscrew it.



Nuts tightening



Ball Seat Carrier adjustment

Easyfit Labelling System

Easyfit Labelling System helps you to customize valves with company brands, serial or identifying numbers or service information such as the function of the valve inside the plant, the conveyed fluid, but also specific information for after selling customer service, such as the customer's name, or date and place of the installation.



More details on www.aliaxis.it/en/tools-and-services/easylabelling-software

VEE Easyfit

DN 10÷50



2-Way Ball Valve

Body material

PVC-U

Ball seats material

PE

Seals material

EPDM

Accessories

Customisation set (LSE)

Transparent protection plug with tag holder (LCE)

Easytorque Kit (KET01)

Hose adaptor (CVPV)

Threaded male ends (CVRV)

d [mm]		16	20	25	32	40	50	63	
DN [mm]		10	15	20	25	32	40	50	
SIZE [inch]		3/8"	1/2"	3/4"	1"	1" 1/4	1" 1/2	2"	Type
ISO-DIN metric series plain female ends	PVC-U	•	•	•	•	•	•	•	VEEIV
BSP series threaded female ends	PVC-U	•	•	•	•	•	•	•	VEEFV
BS socket welding	PVC-U	n.a.	•	•	•	•	•	•	VEELV
ASTM series plain female ends	PVC-U	n.a.	•	•	•	•	•	•	VEEAV
NPT series threaded female ends	PVC-U	n.a.	•	•	•	•	•	•	VEENV
JIS series plain female ends	PVC-U	n.a.	•	•	•	•	•	•	VEEJV
BW Long spigot male ends for butt welding with PE100 SDR 11	PVC-U	n.a.	•	•	•	•	•	•	VEEBEV
PN [bar] 16 bar = 232 psi	PVC-U	16	16	16	16	16	16	16	
Kv100 [l/min]		80	200	385	770	1100	1750	3400	

Notes: n.a.= not available

Multifunctional handle and Easytorque Kit



Easytorque kit is the innovative tool designed by FIP for optimal tightening and adjustment of all threaded components of the Easyfit valves (carriers and nuts) applying a defined and repeatable torque.

The use of the Easytorque wrench is recommended to minimize mechanical stresses on thermoplastic threads, preventing fluid leakage, optimizing ball valve operation and minimizing the wear out of the elastomeric seals.

The use of the Easyfit torque wrench as well as the multifunctional handle also avoids non specific tools causing union nut accidental damaging.



Nuts tightening



Ball Seat Carrier adjustment

Easyfit Labelling System

Easyfit Labelling System helps you to customize valves with company brands, serial or identifying numbers or service information such as the function of the valve inside the plant, the conveyed fluid, but also specific information for after selling customer service, such as the customer's name, or date and place of the installation.



More details on www.aliaxis.it/en/tools-and-services/easylabelling-software

VEE Easyfit DN 65÷100



d [mm]	75	90	110		
DN [mm]	65	80	100		
SIZE [inch]	2" 1/2	3"	4"	Type	
ISO-DIN metric series plain female ends	PVC-U	•	•	•	VEEIV
BSP series threaded female ends	PVC-U	•	•	•	VEEFV
BS socket welding	PVC-U	•	•	•	VEELV
ASTM series plain female ends	PVC-U	•	•	•	VEEAV
NPT series threaded female ends	PVC-U	•	•	•	VEENV
JIS series plain female ends	PVC-U	•	•	•	VEEJV
BW Long spigot male ends for butt welding with PE100 SDR 11	PVC-U	•	•	•	VXEBEV
PN [bar] 16 bar = 232 psi	PVC-U	16	16	16	
Kv100 [l/min]		5000	7000	9400	

2-Way Ball Valve

Body material

PVC-U

Ball seats material

PE

Seals material

EPDM

Accessories

Stem extension (PSE)

Customisation set (LSE)

Transparent protection plug with tag holder (LCE)

Easyfit Power Quick (PQE)

Anti-tampering lock kit (SHE)

Easyfit Quick-release Multifunctional Handle



The innovative Easyfit handle is composed by a central hub fixedly coupled to the valve stem and by a double spoke grip that can be released from the hub with a simple operation.

The handle can also be used as a tool for disassembly, assembly or adjustment of the support of the ball seat carrier.

For this function, once removed the handle from the hub, enter the two upper protrusions into the appropriate slots of the seat carrier to screw or unscrew it.



Ball Seat Carrier adjustment

Easyfit Labelling System

Easyfit Labelling System helps you to customize valves with company brands, serial or identifying numbers or service information such as the function of the valve inside the plant, the conveyed fluid, but also specific information for after selling customer service, such as the customer's name, or date and place of the installation.



More details on www.aliaxis.it/en/tools-and-services/easylabelling-software

SXE Easyfit

DN 10÷50



d [mm]		16	20	25	32	40	50	63	
DN [mm]		10	15	20	25	32	40	50	
SIZE [inch]		3/8"	1/2"	3/4"	1"	1" 1/4	1" 1/2	2"	Type
ISO-DIN metric series plain female ends	PVC-U	•	•	•	•	•	•	•	SXEIV
	PVC-C	•	•	•	•	•	•	•	SXEIC
BSP series threaded female ends	PVC-U	•	•	•	•	•	•	•	SXEFV
BS socket welding	PVC-U	n.a.	•	•	•	•	•	•	SXELV
ASTM series plain female ends	PVC-U	n.a.	•	•	•	•	•	•	SXEAV
	PVC-C	n.a.	•	•	•	•	•	•	SXEAC
Flanged JISK10	PVC-U	n.a.	o.r.	o.r.	o.r.	o.r.	o.r.	o.r.	SXEOJV
	PVC-C	n.a.	o.r.	o.r.	o.r.	o.r.	o.r.	o.r.	SXEOJC
BW Long spigot male ends for butt welding with PE100 SDR 11	PVC-U	n.a.	•	•	•	•	•	•	SXEBEV
PN [bar]	PVC-U	16	16	16	16	16	16	16	
16 bar = 232 psi	PVC-C	16	16	16	16	16	16	16	
Kv100 [l/min]		172	152	258	433	643	928	1343	

Notes: n.a.= not available, o.r.= on request (not in standard production)

True Union Ball Check Valve

Body materials

PVC-U
PVC-C*

Seals materials

EPDM
FKM

Accessories

Customisation Set (LSE)
Easyfit Multifunctional handle (HAVXE)
Easytorque Kit (KET01)

* available only in selected countries, please ask your commercial contact

Multifunctional handle and Easytorque Kit



Nuts tightening

Easytorque kit is the innovative tool designed by FIP for optimal tightening and adjustment of all threaded components of the Easyfit valves (carriers and nuts) applying a defined and repeatable torque.

The use of the Easytorque wrench is recommended to minimize mechanical stresses on thermoplastic threads, preventing fluid leakage, optimizing ball valve operation and minimizing the wear out of the elastomeric seals. The use of the Easyfit torque wrench as well as the multifunctional handle also avoids non specific tools causing union nut accidental damaging.



Ball Seat Carrier adjustment

Easyfit Labelling System

Easyfit Labelling System helps you to customize valves with company brands, serial or identifying numbers or service information such as the function of the valve inside the plant, the conveyed fluid, but also specific information for after selling customer service, such as the customer's name, or date and place of the installation.



More details on www.aliaxis.it/en/tools-and-services/easylabelling-software

SXE Easyfit DN 65÷100



d [mm]		75	90	110	
DN [mm]		65	80	100	
SIZE [inch]		2" 1/2	3"	4"	Type
ISO-DIN metric series plain female ends	PVC-U	•	•	•	SXEIV
	PVC-C	•	•	•	SXEIC
BSP series threaded female ends	PVC-U	•	•	•	SXEIV
	PVC-C	•	•	•	SXEFC
BS socket welding	PVC-U	•	•	•	SXELV
ASTM series plain female ends	PVC-U	•	•	•	SXEAV
	PVC-C	•	•	•	SXEAC
Flanged JIS K10	PVC-U	o. r.	o. r.	o. r.	SXEOJV
	PVC-C	o. r.	o. r.	o. r.	SXEOJC
BW Long spigot male ends for butt welding with PE100 SDR 11	PVC-U	•	•	•	SXEIV
PN [bar]	PVC-U	16	16	16	
16 bar = 232 psi	PVC-C	16	16	16	
10 bar = 150 psi					
Kv 100 [l/min]		2586	3444	5093	
Minimum back pressure [bar] for drop tight service (valve in orizontal position)	PVC-U	0,2	0,2	0,2	
	PVC-C	0,2	0,2	0,2	

Notes: o.r.= on request (not in standard production)

True Union Ball Check Valve

Body materials

PVC-U
PVC-C *

Seals materials

EPDM
FKM

Accessories

Customisation Set (LSE)
Easyfit Multifunctional handle (HSVXE)

* available only in selected countries, please ask your commercial contact

Multifunctional handle



Nuts tightening

The Easyfit multifunctional handle DN 65÷100 is fully compatible with SXE valve and it can be used to tighten or untighten union nuts as well as to disassembly and re-install the main seal carrier of the valve. The handle can be turned into a wrench key for tightening or loosening the union nuts simply engaging the insert housed inside it in the appropriate seat. The tool so composed is extremely rugged and light at the same time offering an excellent ergonomic grip. The insert design engages perfectly on the external profile of the union nuts with a secure grip allowing to exercise a high torque without damaging the nuts in any way. The handle can also be used as a tool for disassembly, assembly or adjustment of the support of the ball seat carrier. For this function, once removed the handle from the hub enter the two upper protrusions into the appropriate slots of the seat carrier to screw or unscrew it.

Easyfit Labelling System



Ball Seat Carrier adjustment

Easyfit Labelling System helps you to customize valves with company brands, serial or identifying numbers or service information such as the function of the valve inside the plant, the conveyed fluid, but also specific information for after selling customer service, such as the customer's name, or date and place of the installation.

More details on www.aliaxis.it/en/tools-and-services/easylabelling-software



SSE Easyfit DN 10÷50



True Union spring Check valve

Body materials

PVC-U
PVC-C

Seals materials

EPDM
FKM

Spring Material

Stainless Steel 316
Hastelloy C276 (only for DN10-25)
A316 PTFE encapsulated (only from DN 32 to DN 50)

Accessories

Customisation Set (LSE)
Easyfit Multifunctional handle (HSVXE)

d [mm]		16	20	25	32	40	50	63	
DN [mm]		10	15	20	25	32	40	50	
SIZE [inch]		3/8"	1/2"	3/4"	1"	1" 1/4"	1" 1/2"	2"	Type
ISO-DIN metric series plain female ends	PVC-U	●	●	●	●	●	●	●	SSEIV
	PVC-C	●	●	●	●	●	●	●	SSEIC
BSP series threaded female ends	PVC-U	●	●	●	●	●	●	●	SSEFV
BS socket welding	PVC-U	n.a.	●	●	●	●	●	●	SSELV
ASTM series plain female ends	PVC-U	n.a.	●	●	●	●	●	●	SSEAV
	PVC-C	n.a.	●	●	●	●	●	●	SSEAC
Flanged JIS K10	PVC-U	n.a.	o. r.	o. r.	o. r.	o. r.	o. r.	o. r.	SSEOJV
	PVC-C	n.a.	o. r.	o. r.	o. r.	o. r.	o. r.	o. r.	SSEJIC
BW Long spigot male ends for butt welding with PE100 SDR 11	PVC-U	n.a.	●	●	●	●	●	●	SSEBEV
PN [bar] 16 bar = 232 psi 10 bar = 150 psi	PVC-U	16	16	16	16	16	16	16	
	PVC-C	16	16	16	16	16	16	16	
Kv100 [l/min]		172	152	258	433	643	928	1343	
Minimum back pressure [bar] for drop tight service (valve in horizontal position)	PVC-U	0,08	0,08	0,08	0,08	0,08	0,08	0,08	
	PVC-C	0,08	0,08	0,08	0,08	0,08	0,08	0,08	

Notes: n.a.= not available, o.r.= on request (not in standard production)

Multifunctional handle



Nuts tightening

The Easyfit multifunctional handle is fully compatible with SSE valves and it can be used to tighten or untighten union nuts. The use of the multifunctional handle is recommended to minimize mechanical stresses on thermoplastic threads, preventing fluid leakage, optimizing ball valve operation and minimizing the wear out of the elastomeric seals. It also avoids non specific tools causing union nut accidental damaging.

Easyfit Labelling System

Easyfit Labelling System helps you to customize valves with company brands, serial or identifying numbers or service information such as the function of the valve inside the plant, the conveyed fluid, but also specific information for after selling customer service, such as the customer's name, or date and place of the installation.

More details on
www.glixaxis.it/en/tools-and-services/easylabelling-software



SSE Easyfit DN 65÷100



d [mm]		75	90	110	
DN [mm]		65	80	100	
SIZE [inch]		2.1/2"	3"	4"	Type
ISO-DIN metric series	PVC-U	•	•	•	SSEIV
plain female ends	PVC-C	•	•	•	SSEIC
BSP series	PVC-U	•	•	•	SSEFV
threaded female ends					
BS socket welding	PVC-U	•	•	•	SSELV
ASTM series	PVC-U	•	•	•	SSEAV
plain female ends	PVC-C	•	•	•	SSEAC
Flanged JIS K10	PVC-U	o. r.	o. r.	o. r.	SSEOJV
	PVC-C	o. r.	o. r.	o. r.	SSEOJC
BW Long spigot male ends for butt welding with PE100 SDR 11	PVC-U	•	•	•	SSEBEV
PN [bar]	PVC-U	16	16	16	
	PVC-C	16	16	16	
16 bar = 232 psi					
10 bar = 150 psi					
Kv100 [l/min]		2586	3444	5093	
Minimum back pressure [bar] for drop tight service (valve in horizontal position)	PVC-U	0,08	0,08	0,08	
	PVC-C	0,08	0,08	0,08	

o.r.= on request (not in standard production)

True Union Spring Check Valve

Body materials

PVC-U
PVC-C

Seals materials

EPDM
FKM

Spring material

Stainless Steel 316
A316 PTFE encapsulated

Accessories

Customisation Set (LSE)
Easyfit Multifunctional handle (HSVXE)

Multifunctional handle



Nuts tightening

The Easyfit multifunctional handle DN65÷100 is fully compatible with SSE valve and it can be used to tighten or untighten union nuts as well as to disassembly and re-install the main seal carrier of the valve. The handle can be turned into a wrench key for tightening or loosening the union nuts simply engaging the insert housed inside it in the appropriate seat. The tool so composed is extremely rugged and light at the same time offering an excellent ergonomic grip. The insert design engages perfectly on the external profile of the union nuts with a secure grip allowing to exercise a high torque without damaging the nuts in any way. The handle can also be used as a tool for disassembly, assembly or adjustment of the support of the ball seat carrier. For this function, once removed the handle from the hub enter the two upper protrusions into the appropriate slots of the seat carrier to screw or unscrew it.

Easyfit Labelling System

Easyfit Labelling System helps you to customize valves with company brands, serial or identifying numbers or service information such as the function of the valve inside the plant, the conveyed fluid, but also specific information for after selling customer service, such as the customer's name, or date and place of the installation.



More details on www.aliaxis.it/en/tools-and-services/easyfit-labelling-software

SR DN 15÷50



d [mm]		20	25	32	40	50	63	
DN [mm]		15	20	25	32	40	50	
SIZE [inch]		1/2"	3/4"	1"	1" 1/4	1" 1/2	2"	Type
ISO-DIN metric series plain male and female ends	PP-H	•	•	•	•	•	•	SRIM
	PVDF	•	•	•	•	•	•	SRIF
Flanged ISO-DIN	PP-H	o. r.	o. r.	o. r.	o. r.	o. r.	o. r.	SROM
	PVDF	o. r.	o. r.	o. r.	o. r.	o. r.	o. r.	SROAM
Flanged ANSI	PP-H	o. r.	o. r.	o. r.	o. r.	o. r.	o. r.	SROAF
	PVDF	o. r.	o. r.	o. r.	o. r.	o. r.	o. r.	SROJF
Flanged JIS K10	PP-H	o. r.	o. r.	o. r.	o. r.	o. r.	o. r.	SROJM
	PVDF	o. r.	o. r.	o. r.	o. r.	o. r.	o. r.	SROJF
BW Long spigot male ends for butt welding with PE100 SDR 11	PP-H	o. r.	o. r.	o. r.	o. r.	o. r.	o. r.	SRUBEM
	PVDF	o. r.	o. r.	o. r.	o. r.	o. r.	o. r.	SRUBM
BW Long spigot male ends for butt welding	PP-H	o. r.	o. r.	o. r.	o. r.	o. r.	o. r.	SRUBM
	PVDF	o. r.	o. r.	o. r.	o. r.	o. r.	o. r.	SRUBF
PN [bar] 16 bar = 232 psi 10 bar = 150 psi	PP-H	10	10	10	10	10	10	
	PVDF	16	16	16	16	16	16	
Kv100 [l/min]		110	205	240	410	650	840	
Minimum back pressure [bar] for drop tight service (valve in horizontal position)	PP-H	0,4	0,4	0,4	0,4	0,4	0,4	
	PVDF	0,2	0,2	0,2	0,2	0,2	0,2	

o.r.= on request (not in standard production)

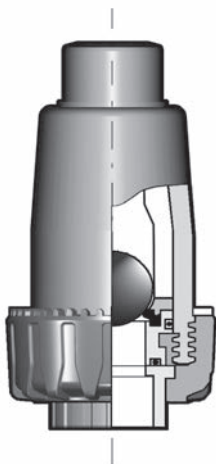

Ball Check Valve

Body materials

PP-H
PVDF

Seals materials

EPDM
FKM

FE

DN 40÷200



d [mm]		50	63	75	90	110	140	160	225	
DN [mm]		40	50	65	80	100	125	150	200	
SIZE [inch]		1" 1/2	2"	2" 1/2	3"	4"	5"	6"	8"	Type
Flangeable according: EN ISO 1452 EN ISO 15493 DIN 2501 ISO 7005-1 EN 1092-1 ASTM B16.5 Cl.150 JIS K5 JIS K10*	PVC-U	•	•	•	•	•	•	•	•	FEOV/..
PN [bar] 16 bar = 232 psi 10 bar = 150 psi 6 bar = 87 psi 4 bar = 58 psi	PVC-U	16	16	10	10	10	10	10	10	
Kv100 [l/min]		1000	1285	1700	3550	5900	9850	18700	30500	

Notes: o.r.= on request (not in standard production)

* JIS K10 8" not applicable.

Butterfly Valve

Body material

PVC-U

Disc material

PVC-U

Stem material

Zinc plated steel (C45)
Stainless Steel AISI 316 o. r.

Seals materials

EPDM
FKM
NBR o.r.

Accessories

Customisation Kit (LSE)

Versions

With handle	FEOV/LM	DN 40 - DN 200
With gear box	FEOV/RM	DN 65 - DN 200

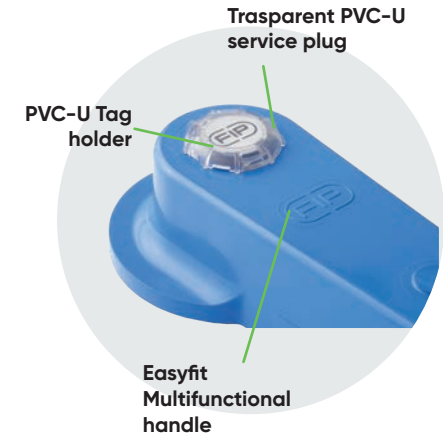

FK DN 40÷400



Butterfly Valve

Body material

PP-GR

Disc materials

PVC-U
PVC-C
PP-H
PVDF

Stem material

Stainless steel 316

Seals materials

EPDM
FKM

Accessories

Limit Switches Installation Kit (FKMS)
Customisation Kit (LSE)
Limit Switch Box (LSQT) + mounting Kit (LSQKIT)

d [mm]		50	63	75	90	110	140	160	225	280	315	355	400	
DN [mm]		40	50	65	80	100	125	150	200	250	300	350	400	
SIZE [inch]		1" 1/2	2"	2" 1/2	3"	4"	5"	6"	8"	10"	12"	14"	16"	Type
Flangeable according: EN ISO 1452 EN ISO 15493 DIN 2501 ISO 7005-1 EN 1092-1 ASTM B16.5 Cl.150 JIS K5* JIS K10**	PVC-U	●	●	●	●	●	●	●	●	●	●	●	●	FKOV/..
	PVC-C	●	●	●	●	●	●	●	●	●	●	n.a	n.a	FKOC/..
	PP-H	●	●	●	●	●	●	●	●	●	●	●	●	FKOM/..
	PVDF	●	●	●	●	●	●	●	●	●	●	●	●	FKOF/..
LUG version DIN	PVC-U	●	●	●	●	●	●	●	●	n.a	●	n.a	n.a	FKOLV/...
	PVC-C	●	●	●	●	●	●	●	●	n.a	●	n.a	n.a	FKOLC/...
	PP-H	●	●	●	●	●	●	●	●	n.a	●	n.a	n.a	FKOLM/...
	PVDF	●	●	●	●	●	●	●	●	n.a	●	n.a	n.a	FKOLF/...
LUG version ANSI	PVC-U	●	●	●	●	●	●	●	●	●	●	n.a	n.a	FKOALV/...
	PVC-C	●	●	●	●	●	●	●	●	●	●	n.a	n.a	FKOALC/...
	PP-H	●	●	●	●	●	●	●	●	●	●	n.a	n.a	FKOALM/...
	PVDF	●	●	●	●	●	●	●	●	●	●	n.a	n.a	FKOALF/...
PN [bar]	PVC-U	16	16	10	10	10	10	10	10	10	8	7	6	
16 bar = 232 psi	PVC-C	16	16	10	10	10	10	10	10	10	8	n.a	n.a	
10 bar = 150 psi	PP-H	10	10	10	10	10	10	10	10	10	8	7	6	
8 bar = 116 psi	PVDF	16	16	10	10	10	10	10	10	10	8	7	6	
6 bar = 87 psi														
PN [bar]	all mater.	10	10	10	10	10	10	10	10	6	6	n.a	n.a	
LUG version														
Kv100 [l/min]		1000	1285	1700	3550	5900	9850	18700	30500	53200	81600	94100	124900	

Notes: n.a.= not available, o.r.= on request (not in standard production)

* JIS K5 2"-14"-16" not applicable. 10"-12" on request

** JIS K10 8"-12" not applicable. 10"-14"-16" on request

FK valves in PVC-U, PP-H and PVDF are available up to 28".
Please ask your commercial contact.

Versions		
With handle	FKO.../LM	DN 40 - DN 200
Bare shaft with actuation flange	FKO.../FM	DN 40 - DN 400
With gear box	FKO.../RM	DN 65 - DN 400

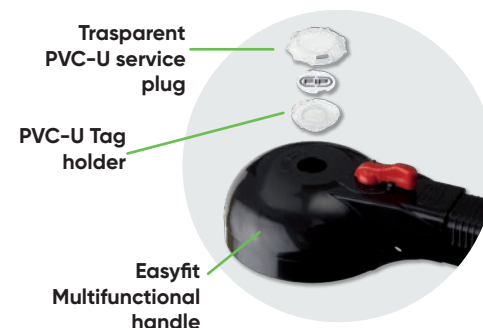

DK DIALOCK®

DN 15÷65

Dialock®



DIALOCK 2-way Diaphragm Valve

Body materials

PVC-U
PVC-C
PP-H
PVDF

Diaphragm materials

EPDM
FKM
PTFE
NBR o.r.

O-Ring materials

EPDM
FKM

Accessories

Wall Mounting Plate (PMDK)
Stroke limiter

d [mm]		20	25	32	40	50	63	75	
DN [mm]		15	20	25	32	40	50	65	
SIZE [inch]		1/2"	3/4"	1"	1" 1/4	1" 1/2	2"	2" 1/2	Type
ISO-DIN metric series plain male ends	PVC-U	●	●	●	●	●	●	●	DKDV
	PVC-C	●	●	●	●	●	●	●	DKDC
	PP-H	●	●	●	●	●	●	●	DKDM
	PVDF	●	●	●	●	●	●	●	DKDF
ISO-DIN metric series unionised plain female ends	PVC-U	●	●	●	●	●	●	n.a.	DKUIV
	PVC-C	●	●	●	●	●	●	n.a.	DKUIC
	PP-H	●	●	●	●	●	●	n.a.	DKUIM
	PVDF	●	●	●	●	●	●	n.a.	DKUIF
BSP series unionised threaded female ends	PVC-U	●	●	●	●	●	●	n.a.	DKUFV
ASTM series unionised plain female ends	PVC-U	●	●	●	●	●	●	n.a.	DKUAV
	PVC-C	●	●	●	●	●	●	n.a.	DKUAC
BS unionised socket welding	PVC-U	●	●	●	●	●	●	n.a.	DKULV
JIS series plain female ends	PVC-U	n.a.	●	●	●	●	●	●	DKUJV
ISO-DIN monolithic flanged structure	PVC-U	●	●	●	●	●	●	●	DKOV
	PVC-C	●	●	●	●	●	●	●	DKOC
	PP-H	●	●	●	●	●	●	●	DKOM
	PVDF	●	●	●	●	●	●	●	DKOF
ANSI monolithic flanged structure	PVC-U	●	●	●	●	●	●	●	DKOAV
	PVC-C	●	●	●	●	●	●	●	DKOAC
	PP-H	●	●	●	●	●	●	●	DKOAM
	PVDF	●	●	●	●	●	●	●	DKOAF
FLANGED JIS K10	PVC-U	●	●	●	●	●	●	●	DKOJV
	PVC-C	o.r.	o.r.	o.r.	o.r.	o.r.	o.r.	o.r.	DKOJC
	PP-H	o.r.	o.r.	o.r.	o.r.	o.r.	o.r.	o.r.	DKOJM
BW Long spigot male ends for butt welding with PE100 SDR 11	PVDF	o.r.	o.r.	o.r.	o.r.	o.r.	o.r.	o.r.	DKOJF
	PVC-U	●	●	●	●	●	●	n.a.	DKUBEV
BW Long spigot male ends for butt welding	PP-H	●	●	●	●	●	●	n.a.	DKUBEM
	PVDF	●	●	●	●	●	●	n.a.	DKUBF
PN [bar] 10 bar = 150 psi	PVC-U	10	10	10	10	10	10	10	
	PVC-C	10	10	10	10	10	10	10	
	PP-H	10	10	10	10	10	10	10	
	PVDF	10	10	10	10	10	10	10	
Kv 100 [l/min]		112	261	445	550	1087	1648	1600	

Notes: n.a.= not available, o.r.= on request (not in standard production)

VM

DN 80÷100



Diaphragm Valve

Body materials

PVC-U
PVC-C
PP-H
PVDF

Diaphragm materials

EPDM
FKM
PTFE
NBR o.r.

O-Ring materials

EPDM
FKM

d [mm]		90	110	
DN [mm]		80	100	
SIZE [inch]		3"	4"	Type
ISO-DIN metric series plain male ends	PVC-U	•	•	VMDV
	PVC-C	•	•	VMDC
	PP-H	•	•	VMDM
	PVDF	•	•	VMDF
ISO-DIN monolithic flanged structure	PVC-U	•	•	VMOV
	PVC-C	•	•	VMOC
	PP-H	•	•	VMOM
	PVDF	•	•	VMOF
ANSI monolithic flanged structure	PVC-U	•	•	VMOAV
	PVC-C	•	•	VMOAC
	PP-H	•	•	VMOAM
	PVDF	•	•	VMOAF
Flanged JIS K10	PVC-U	o. r.	o. r.	VMOJV
	PVC-C	o. r.	o. r.	VMOJC
	PP-H	o. r.	o. r.	VMOJM
	PVDF	o. r.	o. r.	VMOJF
PN [bar] 10 bar = 150 psi 6 bar = 87 psi	PVC-U	* 10	* 10	
	PVC-C	* 10	* 10	
	PP-H	* 10	* 10	
	PVDF	* 10	* 10	
Kv 100 [l/min]		2910	4620	

Notes: o. r. = on request (not in standard production), * 10 = PTFE PN 6

CM

DN 12÷15



Compact Diaphragm Valve

Body materials

PVC-U
PVC-C
PP-H
PVDF

Diaphragm materials

EPDM
FKM
PTFE

O-Ring materials

EPDM
FKM

d [mm]		16	20	
DN [mm]		12	15	
SIZE [inch]		3/8"	1/2"	Type
ISO-DIN metric series unionised plain female ends	PVC-U	n.a.	•	CMUIV
	PVC-C	n.a.	•	CMUIC
	PP-H	n.a.	•	CMUIM
	PVDF	n.a.	•	CMUIF
ISO-DIN metric series plain female ends	PVC-U	•	•	CMIV
	PP-H	•	•	CMIM
ISO-DIN metric series plain male ends	PVC-U	n.a.	•	CMDV
	PP-H	n.a.	•	CMDM
BSP series unionised threaded female ends	PVC-U	n.a.	•	CMUFV
BSP series threaded female ends	PVC-U	•	•	CMFV
	PP-H	•	•	CMFM
	PVDF	•	•	CMFF
BS unionised socket welding	PVC-U	n.a.	o.r.	CMULV
Flanged JIS K10	PVC-U	n.a.	o.r.	CMUJV
ASTM series unionised plain female ends	PVC-U	n.a.	o.r.	CMUAV
	PVC-C	n.a.	o.r.	CMUAC
NPT series unionised threaded female ends	PVC-U	n.a.	o.r.	CMUNV
	PVC-C	n.a.	o.r.	CMUNC
PN [bar] 6 bar = 87 psi	PVC-U	6	6	
	PVC-C	6	6	
	PP-H	6	6	
	PVDF	6	6	
Kv100 [l/min]		47	60	

Notes: n.a.= not available, o.r.= on request (not in standard production)

VM/RM

DN 8÷15



d [mm]		12	
DN [mm]		8	
R [BSP inch]		1/4"	Type
ISO-DIN metric series plain female ends	PVC-U	•	VMIV
BSP series threaded female ends	PVC-U	•	VMFV
PN [bar]	PVC-U	10	

d [mm]		20	
DN [mm]		15	
R [BSP inches]		1/2"	Type
BSP series one male thread one hose adaptor	PVC-U	•	RMRPV
BSP series two male threads	PVC-U	•	RMRV
PN [bar]	PVC-U	4	

Mini Valve and Diaphragm Cock Valve

Body material

PVC-U

Diaphragm material

EPDM

RV

DN 10÷100



Sediment Strainer

Body materials

PVC-U
PVC-U transparent
PVC-C
PP-H

Seals materials

EPDM
FKM

Screen material	PP	PVC	PVC	PVC	PVC	Inox
Hole pitch (mm)	1,5	1,0	1,5	2,0	2,5	0,7
Holes per cm ²	100	190	100	60	35	240
equivalent ASTM mesh size	30	50	35	30	18	35
equivalent hole diameter µm	600	300	500	600	900	500

d [mm]		16	20	25	32	40	50	63	75	90	110	
DN [mm]		10	15	20	25	32	40	50	65	80	100	
Size [inch]		3/8"	1/2"	3/4"	1"	1" 1/4	1" 1/2	2"	2" 1/2	3"	4"	Type
ISO-DIN metric series unionised plain female ends	PVC-U	•	•	•	•	•	•	•	n.a.	n.a.	n.a.	RVUIV
	PVC-U tr.	•	•	•	•	•	•	•	n.a.	n.a.	n.a.	RVUIT
	PVC-C	•	•	•	•	•	•	•	n.a.	n.a.	n.a.	RVUIC
	PP-H	•	•	•	•	•	•	•	n.a.	n.a.	n.a.	RVUIM
ISO-DIN metric series plain female ends	PVC-U	n.a.	n.a.	n.a.	n.a.	n.a.	n.a.	n.a.	•	•	•	RVIV
	PVC-U tr.	n.a.	n.a.	n.a.	n.a.	n.a.	n.a.	n.a.	•	•	•	RVIT
	PP-H	n.a.	n.a.	n.a.	n.a.	n.a.	n.a.	n.a.	•	•	•	RVIM
ISO-DIN metric series plain male ends	PVC-U	•	•	•	•	•	•	•	n.a.	n.a.	n.a.	RVDV
	PVC-U tr.	•	•	•	•	•	•	•	n.a.	n.a.	n.a.	RVDT
BSP series unionised threaded female ends	PVC-U	•	•	•	•	•	•	•	n.a.	n.a.	n.a.	RVUFV
	PVC-U tr.	•	•	•	•	•	•	•	n.a.	n.a.	n.a.	RVUFT
	PP-H	•	•	•	•	•	•	•	n.a.	n.a.	n.a.	RVUFM
BSP series threaded female ends	PVC-U	n.a.	n.a.	n.a.	n.a.	n.a.	n.a.	n.a.	•	•	•	RVFV
	PVC-U tr.	n.a.	n.a.	n.a.	n.a.	n.a.	n.a.	n.a.	•	•	•	RVFT
BS unionised socket welding	PVC-U	o.r.	o.r.	o.r.	o.r.	o.r.	o.r.	o.r.	n.a.	n.a.	n.a.	RVULV
ASTM series unionised plain female ends	PVC-U tr.	•	•	•	•	•	•	•	n.a.	n.a.	n.a.	RVUAT
	PVC-C	•	•	•	•	•	•	•	n.a.	n.a.	n.a.	RVUAC
ASTM series plain female ends	PVC-U tr.	n.a.	n.a.	n.a.	n.a.	n.a.	n.a.	n.a.	n.a.	•	•	RVAT
NPT series unionised threaded female ends	PVC-U tr.	•	•	•	•	•	•	•	n.a.	n.a.	n.a.	RVUNT
	PVC-C	•	•	•	•	•	•	•	n.a.	n.a.	n.a.	RVUNC
	PVC-U tr.	n.a.	n.a.	n.a.	n.a.	n.a.	n.a.	n.a.	n.a.	•	•	RVNT
FLANGED ISO-DIN	PVC-U	n.a.	•	•	•	•	•	•	•	•	•	RVOV
	PVC-U tr.	n.a.	•	•	•	•	•	•	•	•	•	RVOT
	PP-H	n.a.	n.a.	n.a.	n.a.	n.a.	n.a.	n.a.	•	•	•	RVOM
FLANGED ANSI	PVC-U	n.a.	•	•	•	•	•	•	•	•	•	RVOAV
	PVC-U tr.	n.a.	•	•	•	•	•	•	•	•	•	RVOAT
	PP-H	•	•	•	•	•	•	•	n.a.	n.a.	n.a.	RVUOAM
Flanged JIS K10	PP-H	n.a.	n.a.	n.a.	n.a.	n.a.	n.a.	n.a.	•	•	•	RVOAM
	PVC-U	n.a.	o.r.	o.r.	o.r.	o.r.	o.r.	o.r.	o.r.	o.r.	o.r.	RVOJV
	PVC-C	n.a.	o.r.	o.r.	o.r.	o.r.	o.r.	o.r.	o.r.	o.r.	o.r.	RVUOJC
PN [bar] 16 bar = 232 psi 10 bar = 150 psi 6 bar = 87 psi 4 bar = 58 psi	PP-H	n.a.	o.r.	o.r.	o.r.	o.r.	o.r.	o.r.	o.r.	o.r.	o.r.	RVUOJM
	PVC-U	16	16	16	16	16	16	16	10	6	6	
	PVC-U tr.	16	16	16	16	10	10	10	6	4	4	
Kv100 [l/min] Total filtering surface At [cm ²]	PVC-C	n.a.	16	16	16	16	16	16	n.a.	n.a.	n.a.	
	PP-H	n.a.	10	10	10	10	10	10	6	4	4	
		22	40	70	103	188	255	410	650	1050	1700	
		16	16	23,5	36	53	69	101	197	247	396	

Notes: n.a.= not available, o.r.= on request (not in standard production)

PVDF sediment strainers are available in the DN15-100 range. Please ask your commercial contact.

VV

DN 10÷50



Angle Seat Valve

Body material

PVC-U

Seals materials

EDPM/ PTFE
FKM/ PTFE o.r.

d [mm]		16	20	25	32	40	50	63	
DN [mm]		10	15	20	25	32	40	50	
Size [inch]		3/8"	1/2"	3/4"	1"	1" 1/4	1" 1/2	2"	Type
ISO-DIN metric series unionised plain female ends	PVC-U	•	•	•	•	•	•	•	VVUIV
ISO-DIN metric series plain male ends	PVC-U	•	•	•	•	•	•	•	VVDV
BSP series unionised threaded female ends	PVC-U	•	•	•	•	•	•	•	VVUFV
BS unionised socket welding	PVC-U	o.r.	o.r.	o.r.	o.r.	o.r.	o.r.	o.r.	VVULV
ASTM series unionised plain female ends	PVC-U	o.r.	o.r.	o.r.	o.r.	o.r.	o.r.	o.r.	VVUAV
NPT series unionised threaded female ends	PVC-U	o.r.	o.r.	o.r.	o.r.	o.r.	o.r.	o.r.	VVUNV
Flanged ISO-DIN	PVC-U	n.a.	•	•	•	•	•	•	VVOV
Flanged ANSI	PVC-U	n.a.	•	•	•	•	•	•	VVOAV
PN [bar] 16 bar = 232 psi 10 bar = 150 psi	PVC-U	16	16	16	16	10	10	10	
Kv100 [l/min]		47	110	205	375	560	835	1300	

Notes: n.a.= not available, o.r.= on request (not in standard production)

VR

DN 10÷100



Angle Seat Check Valve

Body materials

PVC-U
PP-H

Seals materials

EPDM
FKM

d [mm]		16	20	25	32	40	50	63	75	90	110	
DN [mm]		10	15	20	25	32	40	50	65	80	100	
Size [inch]		3/8"	1/2"	3/4"	1"	1" ¼	1" ½	2"	2" ½	3"	4"	Type
ISO-DIN metric series unionised plain female ends	PVC-U	●	●	●	●	●	●	●	n.a.	n.a.	n.a.	VRUIV
	PP-H	●	●	●	●	●	●	●	n.a.	n.a.	n.a.	VRUIM
ISO-DIN metric series plain female ends	PVC-U	n.a.	n.a.	n.a.	n.a.	n.a.	n.a.	n.a.	●	●	●	VRIV
	PP-H	n.a.	n.a.	n.a.	n.a.	n.a.	n.a.	n.a.	●	●	n.a.	VRIM
ISO-DIN metric series plain male ends	PVC-U	●	●	●	●	●	●	●	n.a.	n.a.	n.a.	VRDV
BSP series unionised threaded female ends	PVC-U	●	●	●	●	●	●	●	n.a.	n.a.	n.a.	VRUFV
	PP-H	n.a.	●	●	●	●	●	●	n.a.	n.a.	n.a.	VRUFM
BSP series threaded female ends	PVC-U	n.a.	n.a.	n.a.	n.a.	n.a.	n.a.	n.a.	●	●	●	VRFV
BS unionised socket welding	PVC-U	o.r.	o.r.	o.r.	o.r.	o.r.	o.r.	o.r.	n.a.	n.a.	n.a.	VRULV
ASTM series unionised plain female ends	PVC-U	o.r.	o.r.	o.r.	o.r.	o.r.	o.r.	o.r.	n.a.	n.a.	n.a.	VRUAV
NPT series unionised threaded female ends	PVC-U	o.r.	o.r.	o.r.	o.r.	o.r.	o.r.	o.r.	n.a.	n.a.	n.a.	VRUNV
Flanged ISO-DIN	PVC-U	●	●	●	●	●	●	●	n.a.	n.a.	n.a.	VRUOV
	PVC-U	n.a.	n.a.	n.a.	n.a.	n.a.	n.a.	n.a.	n.a.	n.a.	n.a.	VROV
	PP-H	●	●	●	●	●	●	●	n.a.	n.a.	n.a.	VRUOM
Flanged ANSI	PP-H	n.a.	n.a.	n.a.	n.a.	n.a.	n.a.	n.a.	●	●	n.a.	VROM
	PVC-U	●	●	●	●	●	●	●	n.a.	n.a.	n.a.	VRUOAV
	PVC-U	n.a.	n.a.	n.a.	n.a.	n.a.	n.a.	n.a.	●	●	●	VROAV
Flanged JIS K10	PP-H	●	●	●	●	●	●	●	n.a.	n.a.	n.a.	VRUOAM
	PP-H	n.a.	n.a.	n.a.	n.a.	n.a.	n.a.	n.a.	●	●	n.a.	VROAM
PN [bar] 16 bar = 232 psi 10 bar = 150 psi 6 bar = 87 psi 4 bar = 58 psi	PVC-U	n.a.	o.r.	o.r.	o.r.	o.r.	o.r.	o.r.	o.r.	o.r.	o.r.	VROJM
	PP-H	n.a.	o.r.	o.r.	o.r.	o.r.	o.r.	o.r.	o.r.	o.r.	n.a.	VROJF
Kv100 [l/min]		47	110	205	375	560	835	1300	1950	2600	3500	

Notes: n.a.= not available, o.r.= on request (not in standard production)

VA

DN 15÷50



d [mm]	20	25	32	40	50	63	
DN [mm]	15	20	25	32	40	50	
R [BSP inch]	1/2"	3/4"	1"	1" ¼	1" ½	2"	Type
ISO-DIN metric series plain male and female ends	PVC-U	•	•	•	•	•	VAIV
BSP series threaded female ends	PVC-U	•	•	•	•	•	VAFV
PN [bar] 16 bar = 232 psi	PVC-U	16	16	16	16	16	

Notes: o.r.= on request (not in standard production)



Air Release Valve

Body material

PVC-U

Seals material

EPDM+PE
EPDM+PTFE o.r.
FKM+PTFE o.r.

VZ

DN 10÷50



d [mm]	16	20	25	32	40	50	63	
DN [mm]	10	15	20	25	32	40	50	
R [BSP inch]	3/8"	1/2"	3/4"	1"	1" ¼	1" ½	2"	Type
ISO-DIN metric series plain male and female ends	PVC-U	•	•	•	•	•	•	VZIV
BSP series threaded female ends	PVC-U	n.a.	•	•	•	•	•	VZFV
PN [bar] 16 bar = 232 psi	PVC-U	16	16	16	16	16	16	
Minimum pressure drop [bar] for piston in the fully open position		0.008	0.008	0.009	0.014	0.017	0.018	0.021
Minimum back pressure [mm H ₂ O] for drop tight service (piston in closed position)		150	150	200	350	350	350	

Notes: n.a.= not available



Foot Valve

Body material

PVC-U

Seals material

EPDM

Accessories

PVC-U Suction strainer (SZIV)

CR

DN 40÷300



d [mm]		50	63	75	90	110	140	160	225	280	315	
DN [mm]		40	50	65	80	100	125	150	200	250	300	Type
ISO-DIN	PVC-U	•	•	•	•	•	•	•	•	•	•	CROV
Working Pressure [bar]	PVC-U	5	5	5	5	5	5	5	5	5	5	
Minimum pressure [bar] for opening with upward flow	PVC-U	0,002	0,003	0,003	0,003	0,003	0,003	0,005	0,005	0,008	0,008	
Minimum back pressure [bar] for drop tight service	PVC-U	0,3	0,3	0,3	0,2	0,2	0,2	0,2	0,2	0,2	0,2	
Kv100 [l/min]		370	900	1250	1867	2867	5700	8167	18800	25000	31900	

Wafer Check Valve

Body material

PVC-U

Seals material

EPDM

NOTE: Other materials and types of Wafer Check Valves can be supplied on request: please ask for type FR to your commercial contact.

Available in PVC-U, PVC-C, PP-H and PVDF with EPDM, FKM and PTFE sealings - with or without stainless steel or hastelloy spring

FR

DN 40÷400



Wafer Check Valve

Body material

PVC-U
PVC-C
PP-H
PVDF

Seals material

EPDM
FKM
PTFE

Spring materials

INOX 316 Ti s.r.
Hastelloy C4 s.r.

d [mm]		40	50	63	75	90	110	140	160	225	280	315	350	400	
DN [mm]		32	40	50	65	80	100	125	150	200	250	300	350	400	
SIZE [inch]		1" 1/4	1" 1/2	2"	2" 1/2	3"	4"	5"	6"	8"	10"	12"	14"	16"	Type
Flangeable according: EN ISO 1452 EN ISO 15493 DIN 2501 ISO 7005-1 EN 1092-1 ASTM B16.5 Cl.150 JIS K5* JIS K10**	PVC-U	●	●	●	●	●	●	●	●	●	●	●	●	●	FROV
	PVC-C	●	●	●	●	●	●	●	●	●	●	●	●	●	FROC
	PP-H	●	●	●	●	●	●	●	●	●	●	●	●	●	FROM
	PVDF	●	●	●	●	●	●	●	●	●	●	●	●	●	FROF
PN [bar]	PVC-U	10	10	10	10	10	10	10	6	6	5	5	5	5	
10 bar = 150 psi	PVC-C	10	10	10	10	10	10	10	6	6	5	5	5	5	
8 bar = 116 psi	PP-H	8	8	8	8	6	6	6	6	6	5	5	5	5	
6 bar = 87 psi	PVDF	10	10	10	10	10	10	10	8	8	5	5	5	5	
5 bar = 72,5 psi															
Minimum pressure [bar] for opening with upward flow without spring		0,002	0,002	0,003	0,003	0,003	0,003	0,003	0,003	0,004	0,004	0,004	0,005	0,007	
Minimum pressure [bar] for opening with upward flow with spring		0,004	0,004	0,005	0,005	0,005	0,005	0,005	0,005	0,006	0,006	0,006	0,007	0,009	
Minimum back pressure [bar] for drop tight service		0,3	0,3	0,3	0,3	0,3	0,3	0,3	0,3	0,3	0,3	0,3	0,3	0,3	
Kv100 [l/min]		270	370	900	1250	1867	2867	5700	8167	18800	25000	31900	46700	67000	

Notes: n.a.= not available, o.r.= on request (not in standard production)

* JIS K5 2"-14"-16" not applicable. 10"-12" on request

** JIS K10 8"-12" not applicable. 10"-14"-16" on request

Up to diameter DN600 are available on request.

Ask your business contact.

SV

DN 15÷25



d [mm]		20	25	32	
DN [mm]		15	20	25	
Size [inch]		1/2"	3/4"	1"	Type
ISO-DIN metric series unionised plain female ends	PVC-U	•	•	•	SVUIV
BSP series unionised threaded female ends	PVC-U	•	•	•	SVUFV
BS unionised socket welding	PVC-U	o.r.	o.r.	o.r.	SVULV
ASTM series unionised plain female ends	PVC-U	o.r.	o.r.	o.r.	SVUAV
NPT series unionised threaded female ends	PVC-U	o.r.	o.r.	o.r.	SVUNV
PN [bar] 16 bar = 232 psi	PVC-U	16	16	16	
Regulation Range [bar]		0.3 ÷ 4			

Notes: o.r.= on request (not in standard production)

Pressure reducing, pressure retaining and pressure relief valves are also available on request. Available materials are PVC-U, PP-H and PVDF, in the range DN 10-100, with EPDM and PTFE diaphragms. Please ask your commercial contact

Angle Seat Pressure Relief Valve

Body material

PVC-U

Seals materials

EPDM

FKM

VKD/CE DUAL BLOCK®

DN 10÷100



Electrically Actuated 2-Way Ball Valve

Body materials

PVC-U
PVC-C
PP-H
PVDF

Ball seats material

PTFE

Seals material

EPDM
FKM

d [mm]		16	20	25	32	40	50	63	75	90	110
DN [mm]		10	15	20	25	32	40	50	65	80	100
SIZE [inch]		3/8"	1/2"	3/4"	1"	1" ¼	1" ½	2"	2" ½	3"	4"

for materials and sizes available see manual valve VKD

PN [bar] 16 bar = 232 psi 10 bar = 150 psi	PVC-U	16	16	16	16	16	16	10*	16	16	16
	PVC-C	16	16	16	16	16	16	10*	16	16	16
	PP-H	10	10	10	10	10	10	10	10	10	10
	PVDF	16	16	16	16	16	16	10*	16	16	16
Kv100 [l/min]		80	200	385	770	1100	1750	3400	5250	7100	9500

* on request PN16

Actuator data	DN 50			DN 65-80			DN 100		
	DC	AC/DC	AC	DC	AC/DC	AC	DC	AC/DC	AC
Voltage [V]	12	24	90÷240	12	24	90÷240	12	24	90÷240
Power [W]	15	15	15	45	45	45	45	45	45
Max Working time [s]	11	12	13	12	13	15	22	22	25
Duty rating CEI34	50%	30%	30%	50%	30%	30%	50%	30%	30%
Protection rate	IP66	IP65	IP65	IP66	IP65	IP65	IP66	IP65	IP65

Working temperature	-10°C/+55°C	
Electrical connections	Power supply	DIN 43650 3P+T
	Limit switches	gland ISO M20
Special versions on request	Different working times	
	IP68	
	Duty 50%	
Actuator standard equipment	ATEX II 2 GD EEx d IIB T6	
	Emergency manual override	
	Visual position indicator	
	2 auxiliary and adjustable limit switches	
	Torque limiter (12V DC)	
Actuator accessories	Positioner 4-20 mA or 0-10 V	
	Fail safe security device (NC or NO)	
	Heating resistor	
	Feedback potentiometer 0.1 - 1 - 5 - 10 Kohm	
	4-20 mA position transmitter	
	2 additional limit switches	
	Torque limiter (24V AC/DC, 90-240 VAC)	

VKD/CP DUAL BLOCK®

DN 10÷100



Pneumatically Actuated 2-Way Ball Valve

Body materials

PVC-U
PVC-C
PP-H
PVDF

Ball seats material

PTFE

Seals materials

EPDM
FKM

Working functions

NC Normally Closed
NO Normally Open
DA Double acting

d [mm]		16	20	25	32	40	50	63	75	90	110
DN [mm]		10	15	20	25	32	40	50	65	80	100
SIZE [inch]		3/8"	1/2"	3/4"	1"	1" 1/4	1" 1/2	2"	2" 1/2	3"	4"

for materials and sizes available see manual valve VKD

Kv100 [l/min]		80	200	385	770	1100	1750	3400	5250	7100	9500
PN [bar] 16 bar = 232 psi 10 bar = 150 psi	PVC-U	16	16	16	16	16	16	16	10*	10*	10*
	PVC-C	16	16	16	16	16	16	16	10*	10*	10*
	PP-H	10	10	10	10	10	10	10	10	10	10
	PVDF	16	16	16	16	16	16	16	10*	10*	10*
Control pressure [bar]		standard 6									
Air Connections	BSP	1/8"	1/8"	1/8"	1/8"	1/4"	1/4"	1/4"	1/4"	1/4"	1/4"
Actuator capacity [L]	DA	0,18	0,18	0,23	0,23	0,45	0,45	0,45	0,45	0,61	0,98
	NC-NO	0,09	0,09	0,12	0,12	0,23	0,23	0,23	0,31	0,49	0,9

* on request PN16

Accessories

Visual position indicator

Pilot solenoid valve 3-5/2 ways	Voltages AC	230-110-24 V
	Voltages DC	24 V
	Protection rate	IP 65

Limit Switches box	LSQT Electromechanical	Contact rate	0.3A (250 VDC) - 0.6A (125 VDC) - 10A (250 VAC)
		Protection rate	IP 67
	LSQT Proximity PNP (3 wires)	Voltage	10-30 V DC
		Current	0-100 mA
		Protection rate	IP68
	Proximity NAMUR (on request)	Voltage	8 V DC
Protection rate		IP 68	
Safety Class		EEex ia IIC T6	

Electropneumatic Positioner	Input signal	4-20 mA
	Protection rate	IP 65

Special versions on request

- SS AISI 304 or SS AISI 316 Pinion
- Aluminium with PTFE coating Caps and Body
- SS AISI 316 Caps and Body (also in polished version)

VKR/CE DUAL BLOCK®

DN 10÷50



Electrically Actuated Regulating Ball Valve

Body materials

PVC-U
PP-H
PVDF

Ball seats material

PTFE

Seals material

EPDM
FKM

d [mm]		16	20	25	32	40	50	63
DN [mm]		10	15	20	25	32	40	50
SIZE [inch]		3/8"	1/2"	3/4"	1"	1" ¼	1" ½	2"

for materials and sizes available see manual valve VKR

PN [bar] 16 bar = 232 psi 10 bar = 150 psi	PVC-U	16	16	16	16	16	16	10*
	PP-H	10	10	10	10	10	10	10
	PVDF	16	16	16	16	16	16	10*
Kv100 [l/min]		83	88	135	256	478	592	1068

* on request PN16

Actuator data	DN 10-50	
	AC/DC	AC
Voltage [V]	12-48 DC, 24 AC	90÷240
Power [W]	15	15
Max Working time [s]	25	25
Duty rating CEI34	50%	50%
Protection rate	IP66	IP66

Working temperature	-10°C/+55°C	
Electrical connections	Power supply	DIN 43650 3P + T
	Limit switches	gland ISO M20
Special versions on request	IP68	
	ATEX II 2 GD Eex d IIB T6	
Actuator standard equipment	Emergency manual override	
	Visual position indicator	
	2 auxiliary and adjustable limit switches	
	Torque limiter	
	Heating resistor	
Actuator accessories	Positioner 4 - 20 mA or 0 -10 V	
	Fail safe security device (NC or NO)	

TKD/CE DUAL BLOCK®

DN 10÷50



Electrically Actuated 3-Way Ball Valve

Body materials

PVC-U
PVC-C
PP-H

Ball seats material

PTFE

Seals materials

EPDM
FKM

Ball configuration

L-bore
T-bore

d [mm]		16	20	25	32	40	50	63
DN [mm]		10	15	20	25	32	40	50
SIZE [inch]		3/8"	1/2"	3/4"	1"	1" ¼	1" ½	2"

for materials and sizes available see manual valve TKD

PN [bar] 16 bar = 232 psi 10 bar = 150 psi	PVC-U	16	16	16	16	16	16	10
	PVC-C	16	16	16	16	16	16	10
	PP-H	10	10	10	10	10	10	10
Kv100 [l/min] with L bore		48	73	150	265	475	620	1220

Actuator data	DN 10-50		
	DC	AC/DC	AC
Voltage [V]	12	24	90÷240
Power [W]	15	15	15
Max Working time [s]	11	12	13
Duty rating CEI34	50%	30%	30%
Protection rate	IP66	IP65	IP65

Working temperature	-10°C/+55°C	
Electrical connections	Power supply	DIN 43650 3P+T
	Limit switches	gland ISO M20
Special versions on request	Different working times	
	IP68	
	Duty 50%	
Actuator standard equipment	ATEX II 2 GD EEx d IIB T6	
	Emergency manual override	
	Visual position indicator	
	2 auxiliary and adjustable limit switches	
	Torque limiter (12V DC)	
Actuator accessories	Heating resistor (for IP66-IP67)	
	Positioner 4-20 mA or 0-10 V	
	Fail safe security device (NC or NO)	
	Heating resistor	
	Feedback potentiometer 0.1 - 1 - 5 - 10 Kohm	
	4-20 mA position transmitter	
	2 additional limit switches	
	3rd position 180°	
	Torque limiter (24V AC/DC, 90-240 VAC)	

TKD/CP DUAL BLOCK®

DN 10÷50



Pneumatically Actuated 3-Way Ball Valve

Body materials

PVC-U
PVC-C
PP-H

Ball seats material

PTFE

Seals materials

EPDM
FKM

Functions

SA (Single Acting)
DA (Double Acting)

Ball configuration

L-bore
T-bore (see details on technical catalogue)

d [mm]	16	20	25	32	40	50	63
DN [mm]	10	15	20	25	32	40	50
SIZE [inch]	3/8"	1/2"	3/4"	1"	1" ¼	1" ½	2"

for materials and sizes available see manual valve TKD

Kv100 [l/min] with L bore		48	73	150	265	475	620	1220
PN [bar]	PVC-U	16	16	16	16	16	16	16
16 bar = 232 psi	PVC-C	16	16	16	16	16	16	16
10 bar = 150 psi	PP-H	10	10	10	10	10	10	10
Control pressure [bar]		standard 6						
Air Connections	BSP	1/8"	1/8"	1/4"	1/4"	1/4"	1/4"	1/4"
Actuator capacity [L]	DA	0,23	0,23	0,45	0,45	0,45	0,45	0,61
	SA	0,12	0,12	0,23	0,23	0,23	0,23	0,31

Accessories

Pilot solenoid valve 3-5/2 ways	Voltages AC	230-110-24 V	
	Voltages DC	24 V	
	Protection rate	IP 65	
Limit Switches box	LSQT Electromechanical	Contact rate	0.3A (250 VDC) - 0.6A (125 VDC) - 10A (250 VAC)
		Protection rate	IP 67
	LSQT Proximity PNP (3 wires)	Voltage	10-30 V DC
Electropneumatic Positioner	Proximity NAMUR (on request)	Current	0-100 mA
		Protection rate	IP68
		Voltage	8 V DC
Special versions on request	Proximity NAMUR (on request)	Protection rate	IP 67
		Safety Class	EEx ia IIC T6
Electropneumatic Positioner	Input signal	4-20 mA	
	Protection rate	IP 65	

Special versions on request

- SS AISI 304 or SS AISI 316 Pinion
- Aluminium with PTFE coating Caps and Body
- SS AISI 316 Caps and Body (also in polished version)

FE/CE

DN 40÷200



d [mm]		50	63	75	90	110	140	160	225
DN [mm]		40	50	65	80	100	125	150	200
SIZE [inch]		1" ½	2"	2" ½	3"	4"	5"	6"	8"

for materials and sizes available see manual valve FE

PN [bar] 16 bar = 232 psi 10 bar = 150 psi	PVC-U	16	16	10	10	10	10	10	10
Kv100 [l/min]		1000	1285	1700	3550	5900	9850	18700	30500

Actuator data	DN 40-50-65			DN 80-100			DN 125-150		DN 200	
	DC	AC/DC	AC	DC	AC/CD	AC	AC/DC	AC	AC/DC	AC
Voltage [V]	12	24	90÷240	12	24	90÷240	24	90÷240	24	90÷240
Power [W]	15	15	15	45	45	45	85	85	85	85
Max Working time [s]	12	12	13	12	13	15	30	30	50	50
Duty rating CEI34	50%	30%	30%	50%	30%	30%	50%	50%	50%	50%
Protection rate	IP66	IP65	IP65	IP66	IP65	IP65	IP66	IP66	IP66	IP66

Electrically Actuated Butterfly Valve

Body material

PVC-U

Disc material

PVC-U

Stem material

Zinc plated steel

Seals materials

EPDM

FKM

NBR o.r.

Working temperature	-10°C/+55°C		
Electrical connections	(DN40-100)	Power supply	DIN 43650 3P+T
		Limit switches	gland ISO M20
	(DN125-300)	Power supply	gland ISO M20
		Limit switches	gland ISO M20
Special versions on request	Different working times		
	IP68		
	Duty 50%		
Actuator standard equipment	ATEX II 2 GD EEx d IIB T6		
	Emergency manual override		
	Visual position indicator		
	2 auxiliary and adjustable limit switches		
	Torque Limiter (DN125-200)		
Actuator accessories	Heating resistor for (IP66-IP67)		
	Positioner 4-20 mA or 0-10 V		
	Fail safe security device (NC or NO)		
	Heating resistor (DN 40-100)		
	Feedback potentiometer 0.1 - 1 - 5 - 10 Kohm		
	4-20 mA position transmitter		
	2 additional limit switches		

Note: o.r.= on request (not in standard production).

FE/CP DN 40÷200



Pneumatically Actuated Butterfly Valve

Body material

PVC-U

Disc material

PVC-U

Stem material

Zinc plated steel

Seals materials

EPDM

FKM

NBR o.r.

Working functions

NC Normally Closed

NO Normally Open

DA Double acting

Note: o.r.= on request (not in standard production).

d [mm]		50	63	75	90	110	140	160	225
DN [mm]		40	50	65	80	100	125	150	200
SIZE [inch]		1" ½	2"	2" ½	3"	4"	5"	6"	8"

for materials and sizes available see manual valve FE

Kv100 [l/min]		1000	1285	1700	3550	5900	9850	18700	30500
PN [bar] 16 bar = 232 psi 10 bar = 150 psi	PVC-U	16	16	10	10	10	10	10	10
Control pressure [bar]		standard 6							
Air Connections	BSP	1/4"	1/4"	1/4"	1/4"	1/4"	1/4"	1/4"	1/4"
Actuator capacity [L]	DA	0,45	0,45	0,45	0,61	0,98	0,98	1,8	2,8
	NC-NO	0,23	0,31	0,31	0,49	0,9	1,4	1,4	4

Accessories

Visual position indicator

Pilot solenoid valve	Voltages AC	230-110-24 V
	Voltages DC	24 V
3-5/2 ways	Protection rate	IP 65

Limit Switches box	LSQT Electromechanical	Contact rate	0.3A (250 VDC) - 0.6A (125 VDC) - 10A (250 VAC)
		Protection rate	IP 67
	LSQT Proximity PNP (3 wires)	Voltage	10-30 V DC
		Current	0-100 mA
		Protection rate	IP68
	Proximity NAMUR (on request)	Voltage	8 V DC
Protection rate		IP 67	
Safety Class		EEx ia IIC T6	

Electropneumatic Positioner	Input signal	4-20 mA
	Protection rate	IP 65

Special version for swimming pool applications available on request

Special versions on request

- SS AISI 304 or SS AISI 316 Pinion
- Aluminium with PTFE coating Caps and Body
- SS AISI 316 Caps and Body (also in polished version)

FK/CE

DN 40÷400



Electrically Actuated Butterfly Valve

Body material

PP-GR

Disc materials

PVC-U
PVC-C
PP-H
PVDF
ABS

Stem material

Stainless steel 316

Seals materials

EPDM
FKM
NBR o.r.

d [mm]		50	63	75	90	110	140	160	225	280	315	355	400
DN [mm]		40	50	65	80	100	125	150	200	250	300	350	400
SIZE [inch]		1" ½	2"	2" ½	3"	4"	5"	6"	8"	10"	12"	14"	16"

for materials and sizes available see manual valve FK

PN [bar] 16 bar = 232 psi 10 bar = 150 psi 8 bar = 116 psi	PVC-U	16	16	10	10	10	10	10	10	10	8	7	6
	PVC-C	16	16	10	10	10	10	10	10	10	8	n. a.	n. a.
	PP-H	10	10	10	10	10	10	10	10	10	8	7	6
	PVDF	16	16	10	10	10	10	10	10	10	8	7	6
PN [bar] Lug version	all mater.	10	10	10	10	10	10	10	10	n.a.	n.a.	n.a.	n.a.
Kv100 [l/min]		1000	1285	1700	3550	5900	9850	18700	30500	53200	81600	94100	124900

Actuator data	DN 40-50-65			DN 80-100			DN 125-150		DN 200		DN 250-400	
	DC	AC/DC	AC	DC	AC/CD	AC	AC/DC	AC	AC/DC	AC	AC/DC	AC
Voltage [V]	12	24	90÷240	12	24	90÷240	24	90÷240	24	90÷240	24*	230
Power [W]	15	15	15	45	45	45	85	85	85	85	-	250
Max Working time [s]	12	12	13	12	13	15	30	30	50	50	-	38
Duty rating CEI34	50%	30%	30%	50%	30%	30%	50%	50%	50%	50%	-	50%
Protection rate	IP66	IP65	IP65	IP66	IP65	IP65	IP68	IP68	IP68	IP68	IP68	IP68

* on request

Working temperature	-10°C/+55°C		
Electrical connections	(DN40-100)	Power supply	DIN 43650 3P+T
		Limit switches	gland ISO M20
Special versions on request	(DN125-300)	Power supply	gland ISO M20
		Limit switches	gland ISO M20
Actuator standard equipment	Different working times		
	IP68		
	Duty 50%		
	ATEX II 2 GD EEx d IIB T6		
Actuator accessories	Emergency manual override		
	Visual position indicator		
	2 auxiliary and adjustable limit switches		
	Torque limiter (DN125-300)		
Actuator accessories	Heating resistor for (DN 125 - 300)		
	Positioner 4-20 mA or 0-10 V		
	Fail safe security device (NC or NO)		
	Heating resistor		
	Feedback potentiometer 0,1 - 1 - 5 - 10 Kohm		
	4-20 mA position transmitter		
2 additional limit switches			

Note: o.r.= on request (not in standard production).

FK/CP

DN 40÷400



Pneumatically Actuated Butterfly Valve

Body material

PP-GR

Disc materials

PVC-U
PVC-C
PP-H
PVDF
ABS

Stem material

Stainless steel 316

Seals materials

EPDM
FKM
NBR o.r.

Working functions

NC Normally Closed
NO Normally Open
DA Double acting

d [mm]		50	63	75	90	110	140	160	225	280	315	355	400
DN [mm]		40	50	65	80	100	125	150	200	250	300	350	400
SIZE [inch]		1" ½	2"	2" ½	3"	4"	5"	6"	8"	10"	12"	14"	16"

for materials and sizes available see manual valve FK

Kv100 [l/min]		1000	1285	1700	3550	5900	9850	18700	30500	53200	81600	94100	124900
PN [bar] 16 bar = 232 psi 10 bar = 150 psi 8 bar = 116 psi	PVC-U	16	16	10	10	10	10	10	10	10	8	7	6
	PVC-C	16	16	10	10	10	10	10	10	10	8	n.a.	n.a.
	PP-H	10	10	10	10	10	10	10	10	10	8	7	6
	PVDF	16	16	10	10	10	10	10	10	10	8	7	6
PN [bar] Lug version	all mater.	n.a.	n.a.	10	10	10	10	10	10	6	6	n.a.	n.a.
Control pressure [bar]		standard 6											
Air Connections	BSP	1/4"	1/4"	1/4"	1/4"	1/4"	1/4"	1/4"	1/4"	1/4"	1/4"	1/4" - 1/2"	1/4" - 1/2"
Actuator capacity [L]	DA	0,45	0,45	0,45	0,61	0,98	0,98	1,8	2,8	4,9	4,9	14,2	14,2
	NC-NO	0,23	0,31	0,31	0,49	0,9	1,4	1,4	4	7,1	7,1	19,2	19,2

Notes: n.a.= not available, o.r.= on request (not in standard production)

Accessories

Visual position indicator

Pilot solenoid valve 3-5/2 ways	Voltages AC	230-110-24 V
	Voltages DC	24 V
	Protection rate	IP 65

Limit Switches box

Limit Switches box	LSQT Electromechanical	Contact rate	0.3A (250 VDC) - 0.6A (125 VDC) - 10A (250 VAC)
		Protection rate	IP 67
	LSQT Proximity PNP (3 wires)	Voltage	10-30 V DC
		Current	0-100 mA
		Protection rate	IP68
	Proximity NAMUR (on request)	Voltage	8 V DC
Protection rate		IP 67	
Safety Class		EEx ia IIC T6	

Electropneumatic Positioner

Electropneumatic Positioner	Input signal	4-20 mA
	Protection rate	IP 65

Special version for swimming pool applications available on request

Special versions on request

- SS AISI 304 or SS AISI 316 Pinion
- Aluminium with PTFE coating Caps and Body
- SS AISI 316 Caps and Body (also in polished version)

DK/CP

DN 15÷65



Pneumatically Actuated 2-way Diaphragm Valve - Piston Type Actuator

Body materials

PVC-U
PVC-C
PP-H
PVDF

Diaphragm materials

EPDM
FKM
PTFE
NBR o.r.

O-Ring materials

EPDM
FKM

Working functions

NC Normally Closed
NO Normally Open
DA Double acting

d [mm]		20	25	32	40	50	63	75
DN [mm]		15	20	25	32	40	50	65
SIZE [inch]		1/2"	3/4"	1"	1 1/4"	1 1/2"	2"	2 1/2"

For materials and sizes available see manual valve DK

Kv100 [l/min]		112	261	445	550	1087	1648	1600
PN [bar] 16 bar = 232 psi 10 bar = 150 psi 8 bar = 116 psi	PVC-U	10	10	10	10	10	10	10
	PVC-C	10	10	10	10	10	10	10
	PP-H	10	10	10	10	10	10	10
	PVDF	10	10	10	10	10	10	10
Control pressure [bar]	NC	max 6 (see graph)						
	NO	max 6 (see graph)						
	DA	max 5 (see graph)						
Air Connections	BSP	1/4"	1/4"	1/4"	1/4"	1/4"	1/4"	1/4"
Actuator capacity [L]	NC	0,12	0,12	0,12	0,12	0,4	0,64	0,64
	NO	0,16	0,16	0,16	0,16	0,41	0,67	0,67
	DA	0,28	0,28	0,28	0,28	0,8	1,3	1,3

Accessories

Stroke limiter with visual position indicator

Stroke limiter with visual position indicator and emergency manual override

Pilot solenoid valve 3/2 ways (Direct or gang mounting)	Voltages AC	230 - 110 - 24 V
	Voltages DC	24
	Protection rate	IP 65

LSLI Electro-mechanical	Contact rate	0,3 A (250 VDC) - 0,6 A (125 VDC) - 10 A (250 VAC)
	Protection rate	IP 67

Limit Switches box (with stroke limiter as an option)	Proximity LSLI PNP (3 wires)	Voltage	10-30 V DC
		Current	0-100 mA
		Protection rate	box: IP67
	Proximity NAMUR (2 wires)	Voltage	8 V DC
		Protection rate	box: IP 65

Electropneumatic Positioner	Input signal	4-20 mA
	Protection rate	IP 65

Notes: o.r.= on request (not in standard production)

Control pressure according to working pressure DK/CP NC

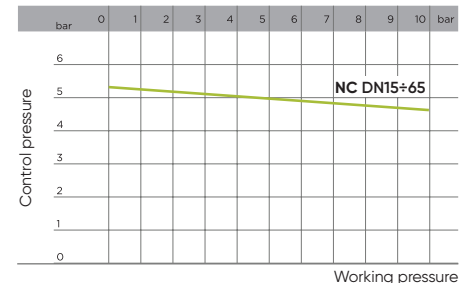

Control pressure according to working pressure DK/CP NO and DK/CP DA

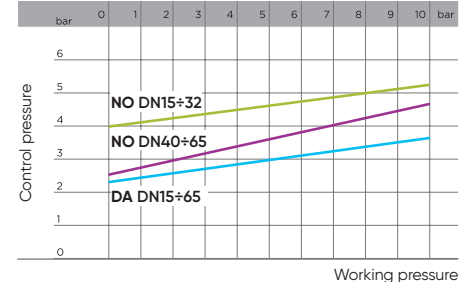

VM/CP

DN 80÷100



Pneumatically Actuated 2-way Diaphragm Valve - Diaphragm Type Actuator

Body materials

PVC-U
PVC-C
PP-H
PVDF

Diaphragm materials

EPDM
FKM
PTFE
NBR o.r.

O-Ring materials

EPDM
FKM

Working functions

NC Normally Closed
NO Normally Open
DA Double acting

d [mm]		90	110
DN [mm]		80	100
SIZE [inch]		3"	4"

For materials and sizes available see manual valve VM

Kv100 [l/min]		2910	4620
PN [bar] 16 bar = 232 psi 10 bar = 150 psi 8 bar = 116 psi	PVC-U	6	6
	PVC-C	6	6
	PP-H	6	6
	PVDF	6	6
Control pressure [bar]	NC	max 6 (see graph on FIP catalogue)	
	NO-DA	max 5 (see graph on FIP catalogue)	
Air Connections	BSP	1/4"	1/4"
Actuator capacity [L]	NC	2,10	2,5
	NO	2,20	2,5
	DA	4,3	5,0

Accessories

Visual position indicator

Stroke limiter with visual position indicator

Stroke limiter with visual position indicator and emergency manual override

Pilot solenoid valve 3/2 ways	Voltages AC	230 - 110 - 24 V		
	Voltages DC	24		
	Protection rate	IP 65		
Limit Switches box	LSLI Electromechanical	Contact rate	0,3 A (250 VDC) - 0,6 A (125 VDC) - 10 A (250 VAC)	
		Protection rate	IP 67	
	Proximity LSLI PNP (3 wires)	Voltage	10-30 V DC	
		Current	0-100 mA	
		Protection rate	box: IP67	
	Proximity NAMUR (2 wires)	Voltage	8 V DC	
Protection rate		box: IP 65		
Electropneumatic Positioner	Input signal	4-20 mA		
	Protection rate	IP 65		

Note: o.r. = on request (not in standard production)

DKD/CP DN 15÷65



Direct Action Pneumatically Actuated 2-way Diaphragm Valve

Body materials

PVC-U

Diaphragm materials

EPDM
NBR o.r.

O-Ring materials

EPDM

Functions

NO (Normally Open)

d [mm]		20	25	32	40	50	63	75
DN [mm]		15	20	25	32	40	50	65
SIZE [inch]		1/2"	3/4"	1"	1" 1/4	1" 1/2	2"	2" 1/2
Kv100 [l/min]		112	261	445	550	1087	1648	1600
PN [bar] 10 bar = 150 psi	PVC-U	10	10	10	10	10	10	10
Control pressure [bar]	max 10 (see graph)							
Air Connections	BSP	1/4"	1/4"	1/4"	1/4"	1/4"	1/4"	1/4"
Actuators capacity [L]	NO	0.13	0.13	0.28	0.28	0.50	0.50	0.50

Accessories

Pilot solenoid valve 3/2 ways (Direct mounting)	Voltages AC	230 - 110 - 48 - 24 V
	Voltages DC	110 - 24 - 12 V
	Protection rate	IP 65

Note: o.r. = on request (not in standard production)

Control pressure according to working pressure DKD/CP NO

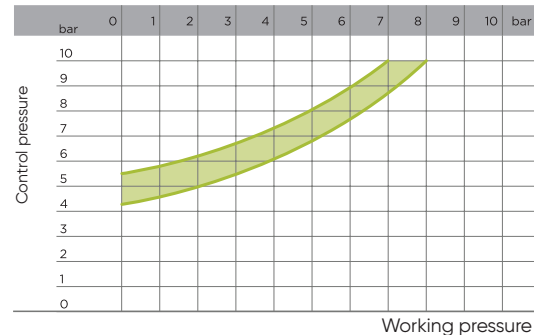

Note: for versions DN50 and DN65, in order to allow the complete opening of the valve, the operating pressure of the fluid in line must be at least 1.2 bar.

CK/CP DN 12÷15



DUALBLOCK® pneumatically actuated compact diaphragm valve

Body materials

PVC-U
PVC-C
PP-H
PVDF

Diaphragm materials

EPDM
PTFE/EPDM
(FKM and NBR on request)

O-Ring materials

EPDM
FKM

Working functions

NC Normally Closed
NO Normally Open
DA Double acting (on request)

d [mm]		16	20
DN [mm]		12	15
SIZE [inch]		3/8"	1/2"
Kv100 [l/min]		51	61
PN [bar] 6 bar = 87 psi	PVC-U	6	6
	PVC-C	6	6
	PP-H	6	6
	PVDF	6	6
Control pressure [bar]		min/max 2-6 (see graph)	
Air Connections	BSP	1/4"	1/4"
Actuator capacity [L]		NC: 0,036	NC: 0,036
		NO: 0,036	NO: 0,036
		DA: 0,072	DA: 0,072

Accessories				
Pilot solenoid valve (Direct or gang mounting)	Voltages AC	230 - 110 - 24 V		
	Voltages DC	24		
	Protection rate	IP 65		
Limit Switches box	Electromechanical	Contact rate	250 V-5 A	
		Protection rate	IP 65	
	Proximity NAMUR (2 wires)	Voltage	8 V DC	
		Protection rate	box: IP 65	

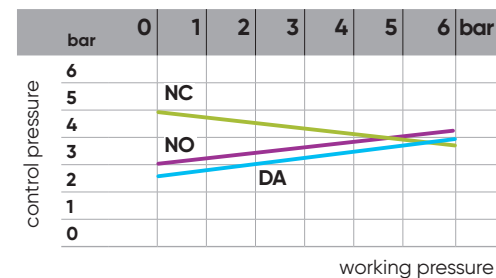

S12/S22

DN 4÷15

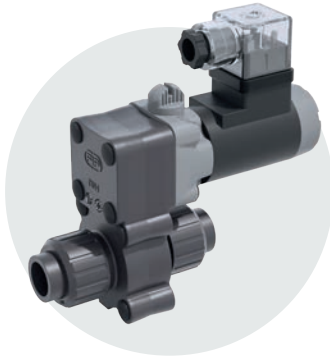

2-way Solenoid Valve

Body material

PVC-U

Seals materials

EPDM
FKM

	S12				S22				
	d [mm]	16	16	16	16-20	16-20	16-20		
DN [mm]	4	6	8		8	10	15		
R [inch]	1/4"- 3/8"	1/4"- 3/8"	1/4"- 3/8"	Type	3/8"-1/2"	3/8"-1/2"	3/8"- 1/2"	Type	
ISO-DIN metric series plain female ends	PVC-U	n.a.	n.a.	n.a.	S12IV	•	•	•	S22IV
BSP series threaded female ends	PVC-U	n.a.	•	•	S12FV	•	•	•	S22FV
BS socket welding	PVC-U	only 3/8"	only 3/8"	only 3/8"	S12LV	•	•	•	S22LV
ASTM series plain female ends	PVC-U	n.a.	n.a.	n.a.	-	•	•	•	S22AV
NPT series threaded female ends	PVC-U	n.a.	n.a.	n.a.	S12NV				
PN [bar] 6 bar = 87 psi 4 bar = 58 psi 2 bar = 29 psi	PVC-U	6	4	2		6	4	2	
Kv100 [l/min]		6,7	12,1	15,3		27,5	34,2	58,3	
Voltages	a.c. (*)	230 - 110 - 24			50/60 Hz other voltages				
	d.c.				24 other voltages				
Power consumption		10 W			20 W				
Duty		100% ED							
Protection rate		IP65							

(*) the coils are RAC (rectifier alternate current): use the plug supplied with the valve, that includes the rectifier.

STANDARD REFERENCES (DIMENSIONS)

	Solvent Welding		Socket Fusion		Threaded couplings	Flanged couplings	Butterfly Valves overall dimensions
		Relevant Pipe Standard		Relevant Pipe Standard			
PVC-U	EN ISO 1452	EN ISO 1452			ISO 228-1	ISO 7005-1	(all materials)
	EN ISO 15493	EN ISO 15493			DIN 2999	EN ISO 1452	EN ISO 1452
	BS 4346-1	DIN 8062			ASTM D 2464	EN ISO 15493	EN ISO 15493
	DIN 8063	NF T54-016			JIS B 0203	EN 558-1	DIN 2501
	NF T54-028	ASTM D 1785				DIN 2501	ISO 7005-1
	ASTM D 2467	JIS K 6741				ANSI B.16.5 cl.150	EN 1092-1
	JIS K 6743					JIS B 2220	ASTM B16.5 Cl.150
PVC-C	EN ISO 15493	EN ISO 15493			ISO 228-1	ISO 7005-1	JIS B2220
	ASTM F 439	ASTM F 441			DIN 2999	EN ISO 15493	EN ISO 16136
					ASTM F437	EN 558-1	
						DIN 2501	
						ANSI B.16.5 cl. 150	
PP-H			EN ISO 15494	EN ISO 15494	ISO 228-1	ISO 7005-1	
					DIN 2999	EN 1092-1	
						EN ISO 15494	
						EN 558-1	
						DIN 2501	
PVDF			EN ISO 10931	ISO 228-1		EN ISO 10931	
				DIN 2999		DIN 2501	
						ISO 7005-1	
						EN 1092-1	
						ASTM B16.5 Cl.150	



FIP Formatura Iniezione Polimeri

Loc. Pian di Parata, 16015 Casella Genova Italy

Tel. +39 0109621.1 - Fax +39 010 9621.209

info.fip@alixis.com

www.alixis.it

UNI EN
ISO 9001
QUALITÀ

UNI EN
ISO 9001
QUALITÀ

